

2023

Requirements for Construction of Water & Sewer



PUBLIC WORKS

IVGID COMPLIANCE DIVISION

Incline Village GID

1/1/2023

IVGID REQUIREMENTS FOR CONSTRUCTION OF WATER & SEWER

TABLE OF CONTENTS

Table of Contents	1
Need to Know Information	2
Article 1. GENERAL SPECIFICATIONS	8
Article 2. WATER SERVICE LINE SPECIFICATIONS	10
Article 3. WATER METER SPECIFICATIONS	13
Article 4. FIRE SYSTEM SPECIFICATIONS.....	13
Article 5. DISTRICT REGULATIONS FOR BOILER/MECHANICAL SYSTEMS.....	14
Article 6. DISTRICT REGULATIONS FOR IRRIGATION SYSTEMS.....	15
Article 7. REGULATIONS FOR PRIVATE BACKFLOW TESTING	15
Article 8. SEWER SERVICE SPECIFICATIONS.....	15
Article 9. INDIVIDUAL SEWER PUMP STATIONS.....	21
Article 10. COMMUNAL UTILITY SYSTEM SPECIFICATIONS	23
Article 11. JOINT TRENCHING SPECIFICATIONS.....	23
Article 12. IVGID APPROVED INSTALLATION DETAILS	23

IVGID REQUIREMENTS FOR CONSTRUCTION OF WATER & SEWER

NEED TO KNOW INFORMATION

IVGID Codes of Enforcement:

- The current approved edition of the (UPC) Uniform Plumbing Code.
- Nevada Administrative Code (NAC water controls).
- Nevada Revised Statutes (NRS water controls).
- Ten State Standards.
- Incline Village General Improvement District Ordinances 1, 2, 4

Plan checking information that is needed but often missed:

- All Utility Easements.
- Fences and their locations identified on the plans.
- All locations of new private water and sewer utility lines and their details.
- Lawn irrigation system(s) complying with all IVGID 33% rules and regulations.

Agency requiring additional Permitting

- **NDOT Permit:** Nevada Department of Transportation oversees state roadways and Right-Of-Ways in which your project may need approval for your project. The designer consultant is responsible to prepare all documentation as required by the terms and conditions relating to the Right-Of-Way Occupancy Permit.
- NDOT Link
- [638024470064270000 \(nv.gov\)](https://www.ndot.gov)
- North Lake Tahoe Fire Protection District located at 866 Oriole Way, Incline Village, NV 89451. The NLTFPD reviews/approves all Fire Sprinkler Systems designs and types. IVGID approves all water connection points to the potable water system supplying all fire systems.

Water service line abandonment: Contact IVGID Pipeline Supervisor at 775-832-1289 and schedule a water service line freeze.

Construction Types:

- Interior/exterior remodel only with no additional water or sewer fixture units.
- Interior/exterior remodel with additional water and sewer fixture units identified on plans.
- All Demo/New Construction with additional water or sewer fixture units identified on plans.

Interior/exterior remodel only no additional water or sewer fixture units.

- When a project requires a Fire Sprinkler System?
 - Designer can indicate on plans that a fire sprinkler system is required and the size of water tap needed for this fire sprinkler system. Review water details within this document.
- Cross-Connection-Control-Devices must be indicated on plans in a location such as a mechanical room or dedicated area approved by IVGID.
- Type of heating system.
- Lawn landscaping system.
- Location of the water pressure regulator.
- Grade elevation for a sewer backwater valve.

IVGID REQUIREMENTS FOR CONSTRUCTION OF WATER & SEWER

Interior/exterior remodel with additional Water and Sewer fixture units identified on plans

- When a project requires a Fire Sprinkler System?
 - Designer can indicate on plans that a fire sprinkler system is required and the size of water tap needed for this fire sprinkler system. Review water details within this document.
- Cross-Connection-Control-Devices must be indicated on plans in a location such as a mechanical room or dedicated area approved by IVGID.
- Water line must be identified on the plans complying with all UPC requirements.
- Sewer line must be identified on the plans complying with all UPC requirements.
- All water meter(s) and their location(s) must be identified on the plans and located at the parcel property corner of said parcel. Unless approved by an agent of the district.
- All water and sewer utility easements to be identified on the plans.
- All, fences too be identified on the plans.
- Type of heating system; to be identified on the plans.
- Lawn Irrigation systems; to be identified on the plans.
- If this project requires a water meter upgrade, then the parcel would require a property survey identifying all property corners and lines.
- Grade elevation for a sewer backwater valve.
- When a project requires a sewer lift pump station located outside of the footprint refer to IVGID sewer detail pump station documents within this document.

Demo/New Construction with additional Water and Sewer fixture units identified on plans.

- Parcel must have a survey identifying all property corners and lines.
- Complete a Washoe County Demo permit application.
 - (No existing structure then no requirements for a demo permit is needed).
- When a project requires a Fire Sprinkler System?
 - Designer can indicate on plans that a fire sprinkler system is required and the size of water tap needed for this fire sprinkler system. Review water details within this document.
- Cross-Connection-Control-Devices must be indicated on plans in a location such as a mechanical room or dedicated area approved by IVGID.
- Water line must be identified on the plans complying with all UPC requirements.
- Sewer line must be identified on the plans complying with all UPC requirements.
- All water meter(s) and their location(s), must be identified on the plans and located at the parcel property corner of said parcel. Unless approved by an agent of the district.
- All water and sewer utility easements, too be identified on the plans.
- All fences, to be identified on the plans.
- Type of heating system to be identified on the plans.
- Lawn Irrigation systems to be identified on the plans.
- Grade elevation for a sewer backwater valve.
- When a project requires a sewer lift pump station located outside of the footprint refer to sewer information/documents within this document.

IVGID REQUIREMENTS FOR CONSTRUCTION OF WATER & SEWER

DEFINITIONS

District

Incline Village General Improvement District (IVGID).

District Engineer

The Engineer appointed and acting for the District and shall be a Registered Civil Engineer in the State of Nevada.

Agent or IVGID Inspectors:

IVGID employees within the department known as the Compliance Division review construction plans, Cross-Connection-Control-Program, Grease Program, and all field Water Distribution inspections as well as Sewer Collection Systems.

Pipeline Distribution/Collection/Supervisor: Contact (775) 832-1289 for all water and sewer utility line location(s) and request for freezing of existing water lines.

Permit

Any written authorization required pursuant to this or any other regulation of District for the installation of any water works.

Permit Parcel Owner:

Responsible for all cost created by the request of the Washoe County Permit such as but not limited to Plan Review Fees, Construction Cost, Utility Connection Fees, Washoe County Street Cuts, Utility Easements, and or all water and sewer utility apparatus which are needed in efforts of complying to all Nevada State Health Codes and or the IVGID utility ordinances.

Plan Checking Process:

The District current working with the Washoe County Building Department and using the Washoe County Building Department Permit Process and Permit # for project final. To speed up your requested plan review process the district request that all but not limited to: Utility Easements, existing or new fire sprinkler systems, water and sewer utilities lines, backflow devices, pressure regulators, proposed fences, lawn irrigation system.

Plan Check Fee.

In accordance with the District's most recently adopted revision of the Uniform Plumbing Code, a plan check fee shall be required for all plans requiring the District's approval. Each plan revision requiring rechecking shall necessitate the charge of an additional plan check fee. Plan checking is performed for both water and sewer considerations concurrently. Only one plan check fee is collected per set of drawings, even if both water and sewer systems are affected. Plan check fees shall be invoiced at a rate as shown in Exhibit C, and are subject to change from time to time at the discretion of the Director of Public Works.

IVGID REQUIREMENTS FOR CONSTRUCTION OF WATER & SEWER

Inspection Fee.

Inspection fees shall be at rate as shown in Exhibit C, and are subject to change from time to time at the discretion of the Director of Public Works.

Cross-Connection

Any physical connection or arrangement of piping or fixtures between two otherwise separate piping systems, one of which contains potable water and the other non-potable water or industrial fluids of questionable safety, through which, or because of which backflow may occur into the potable water system. All new installation of water piping greater than 2" are considered a lethal cross-connection and must be protected with an Air Gap until all approved disinfection process have been completed to all IVGID approval. Contractor cannot make a physical connection to the IVGID Potable water system until the contractor receives written approval from the Agent/inspector from the district.

Hazard, Degree of.

The term is derived from an evaluation of the potential risk to public health and the adverse effect of the hazard upon the potable water system.

- (1) Lethal Hazard, Any conditions, devices, or practice in the water supply system and its operations, which could create or may create a fatal to the health and well-being of the water consumer or water system by a biological or living organisms being created within the water system.
- (2) Hazard - Health. Any condition, device, or practice in the water supply system and its operation, which could create or may create a danger to the health and well-being of the water consumer.
- (3) Hazard - Pollution. An actual or potential threat to the physical properties of the water system or the consumer's potable water system, which constitutes a nuisance or is aesthetically.

Backflow Prevention/CCC&Program

The District reserves the right to require the installation of an approved backflow prevention assembly.

(1) No water service connection to any premises may be installed or maintained by the District unless an Air Gap, RPA, DC, PVB or SVB as required by State laws and regulations and this ordinance protects the water supply. Service of water to any premises may be discontinued by the District if a backflow prevention assembly has been removed, bypassed, or if an unprotected cross-connection exists on the premises. Service will not be restored until such conditions or defects are corrected. The IVGID inspector shall determine what approved backflow device is approved for each Degree of Hazard present.

(2)The customer's system shall be open for inspection at all reasonable times to authorized representatives of District to determine whether cross-connections or other structural or sanitary hazards exist. When such a hazard becomes known, the Director of Public Works may deny or discontinue service to the premises by providing for a physical break (AG) in the service line until the customer has corrected the condition(s) in conformance with state law and local ordinances relating to plumbing and water supplies and any regulations adopted pursuant thereto.

IVGID REQUIREMENTS FOR CONSTRUCTION OF WATER & SEWER

Air-gap.

The unobstructed vertical distance through the free atmosphere between the lowest opening from any pipe or faucet supplying water to a tank, plumbing, fixture, or other device and the flood level rim of said vessel. An approved air-gap shall be at least double the diameter of the supply pipe, measured vertically, above the overflow rim of the vessel, and in no case less than one inch. Any air gap placed near sidewalls, ribs or similar obstructions shall be a distance greater than three times the diameter of the effective opening.

Note: All new water services greater than 2 inches must maintain an approved air gap until all disinfection processes have been approved by the district agents and the contractor receives an approved written notification allowing the contractor to make a physical water connection to the IVGID Potable Distribution Water System(s).

Customer Service Line

All piping between the house piping and the service connections.

House Piping

All piping and fittings installed within the house or building, up to and including the last fitting inside or outside the wall.

Inspector

That person so designated by the District Engineer to perform inspections, tests, fixture unit counts, and related work in determining compliance with IVGID construction specifications, standards and ordinances.

Private Communal Water System

Any system served by District water under the responsibility for maintenance by others and ownership by others. All private communal water system must comply with all IVGID water and sewer ordinances approved by the Incline Village General Improvement District Public Works Director and the Board of Directors of IVGID.

Customer Service Valve on the Customers Property

The Customer shall provide a valve on his side of the service installation, as close to the meter location as practicable, to control the flow of water to the piping on his premises. The Customer shall not use the meter curb stop to turn water on and off.

Uniform Plumbing Code/IAPMO

- A. The following Uniform Plumbing Code provisions are made a part of this ordinance.
- B. By this Ordinance revision all reference to and use of the current adopted version of the Uniform Plumbing Code and the International Association of Plumbing and Mechanical Officials (IAPMO) Installation Standards, as approved by the Director of Public Works and all other ordinances or parts

IVGID REQUIREMENTS FOR CONSTRUCTION OF WATER & SEWER

of ordinances in conflict with the hereafter adopted new ordinance revision are herewith and hereby repealed.

- C. District Ordinances 2 and 4, as accepted and amended; supersede any UPC requirements and definitions, which differ.

Required Assignment of Water Rights.

- A. In addition to compliance with all other standards for granting applications for connections, all applicants shall be required to assign to the District any and all water rights for the parcel, which may be used to help meet the projected water demand of the applicant's project.
- B. All applicants for multi-family residential, tourist accommodation unit, public service and commercial developments are required to assign water rights to IVGID in an amount sufficient to support the proposed development as a condition of project approval (i.e., issuance of will serve letter, sign off on condo plat, approval of plans, etc.) Water rights assigned to IVGID as a condition of project approval will not revert back to the applicant that assigned these rights. All assignment of water rights to IVGID shall be completed and approved by State's Engineers Office.

NDOT Permit: Nevada Department of Transportation oversees state roadways and Right-Of-Ways in which your project may need approval for your project. The designer consultant is responsible to prepare all documentation as required by the terms and conditions relating to the Right-Of-Way Occupancy Permit. NDOT Link [638024470064270000 \(nv.gov\)](https://www.ndot.gov/638024470064270000)

Violation

Any person found to be violating any provision of this or any Ordinance, rule or regulation of the District, shall be served by the Inspector or other authorized person with written notice stating the nature of the violation and providing a reasonable time limit for the satisfactory correction thereof. Said time limit shall be ten (10) business days. The offender shall within the period of time stated in such notice, permanently cease all violations. All persons shall be held strictly responsible for all acts of their agents or employees done under the provisions of this or any other Ordinance, rule or regulation of the District. Upon being notified by the Inspector of any violation of this Ordinance, the person or persons having charge of said work shall immediately correct the same.

- A. Amounts. Violations of these Regulations shall be subject to civil monetary penalties established by
 - (1) Applicable Nevada statutes or administrative code;
 - (2) Nevada Environmental Protection Division and the District, and
 - (3) By such penalty schedules as may from time to time be adopted by the District and appended to To these regulations.
- B. Continuing Violations. For purposes of the computation of penalties, each day of a continuing Violation of these Regulations shall be deemed a separate violation.

IVGID REQUIREMENTS FOR CONSTRUCTION OF WATER & SEWER

Article 1. GENERAL SPECIFICATIONS

- 1.01** IVGID shall give an approximate location and size of all district utility lines, It's the property owner's or their agents responsibility to field locate and confirm utility locations and sizes before digging or cutting any street(s). All street cut permits are approved by the Washoe County Road Division not IVGID.
- 1.02** These requirements are applicable within the jurisdiction of the Incline Village General Improvement District (The District) for the building of water and sewer service lines from the property or easement line to the house or building and within existing rights-of-way (ROW). Service lines on private property shall be constructed and maintained by the property owner in accordance with these requirements.
- 1.03** **Codes:** Building sewer and water service lines shall be constructed in accordance with the latest edition of:
- A. The current Uniform Plumbing Code (UPC) adopted by the Board of Trustees, as prepared by the International Association of Plumbing and Mechanical Officials, except for particular requirements in excess of the Codes, as stated herein.
 - B. The Nevada Administrative Code, 445A Water Operations
 - C. The Incline Village GID Ordinances, as passed by the IVGID Board of Trustees.
- 1.04** **Plans:** All connection fees must be paid before the District will approve plans for construction, inspect service lines, or install water meters. The Washoe County Building Department requires evidence that the District has examined the plans prior to building permit issuance for all water, sewer and trash related projects within the District. Water and sewer taps require scheduling for inspections at least 48 hours in advance. Line locations must be confirmed prior to any excavations. Any application that has been accepted by the District shall be considered vacated if the Applicant fails to commence construction and connection to the District's water system within 540 days of such acceptance. The fees collected for such application shall be returned to the Applicant, upon written request, and a new application and payment of fees will be required before service will be provided. Connection fees shall be charged at the rate in effect on the day of application for a Building Permit from Washoe County. Connection(s) not made within 540 days will be subject to the current rates in effect at the time of connection. Previously paid connection fees shall be credited to the new connection fee rate. Payment of connection fees constitutes acceptance of a new service connection application by the District. No fees will be refunded after connection.
- 1.05** **Fire Marshal Review:** The District does not review a project to determine the need for fire sprinkler lines. The applicant is advised to contact the North Lake Tahoe Fire Protection District (NLTFPD) at (775)831-0351 to determine the availability of adequate fire protection and the potential need of a fire sprinkler system. A sprinkler system may require a separate service line tapped to the Districts water main as determined by the Fire Dept. In some cases a two headed calculation may be allowed, eliminating the need for a new tap and street cuts. All unmodified systems will be referred to as R-13 systems. The potable water service line if used in conjunction with fire service must be approved by the District and delineation at the property line by means of a separate valve, a riser pipe with a properly boxed enclosure. All Fire lines shall be metered. The NLTFPD will make available their "Fire

IVGID REQUIREMENTS FOR CONSTRUCTION OF WATER & SEWER

Prevention Bureau Standard Operation Procedure" upon request. Their formal review of the plans will occur in conjunction with the District review; however, District approval may not be gained prior to NLTFPD approval.

- 1.06 Inspection:** No backfilling shall be performed until the District has inspected and approved the installation for covering. The contractor shall schedule all inspections at least forty-eight (48) hours in advance. All testing shall be performed in the presence of an authorized representative of the District. Inspection fees shall be set by the District and charged for each inspection.
- 1.07 Abandonment of Connection Points:** All existing water and or sewer connection points must be completed to all IVGID specifications by means of a Full Circle Repair Clamps or other means approved by the district agent/inspector.
- 1.08 Water service line abandonment:** Contact IVGID Pipeline Supervisor at 775-832-1289 to schedule a water service line freeze.
- 1.09 Corrections Notice:** Written/verbal instructions to complete job(s) to all code requirements.
- 1.10 Conditional Final:** A Conditional Final may be given at the discretion of IVGID Compliance. In this case, the Washoe County Building Department will sign off on the permit, and IVGID will hold the contractor/owner responsible for completing all IVGID requirements. A written acknowledgement from contractor/owner may be required and must be approved by IVGID Compliance.
- 1.11 Re-Inspection:** If not ready for scheduled inspection, please call 775-832-1224 for cancellation. A fee may be charged at a rate set by the District for re-inspection if the site is not ready for inspection, or if the initial inspection fails.
- 1.12 Utility Connections:** All water service and building sewer connections shall comply with one of the following conditions, whichever is applicable.
- 1.13 Single Family Residence:** Where a single-family residence is constructed on a single parcel, direct connection to the public water and sewer system shall be made. Should the parcel not border upon the easement or dedicated right-of-way containing the public utilities, it is the property owner's responsibility to obtain the necessary easements and/or construct main extensions as determined to be necessary by the District. Reimbursement for main extensions is provided should additional connections be made to the extended main within a ten-year period in accordance with the standard "District Main Extension Agreement."
- 1.14 Multiple Residences with Common Land Ownership / Commercial Developments:** A development with more than one residential building with common land ownership shall be served by communal water and sewer systems. The development shall be metered near the point where the service line crosses the property line and each unit shall be served by an individual meter, however the only meter read for billing purposes is the master meter. The District shall approve the number, location and size of meter(s). IVGID reserves the right to meter parcels as it sees fit for the benefit of the general public. The operation and maintenance of the system as well as payment of fire protection fees shall be the responsibility of the owner(s) of the property served or of the association having legal responsibility for buildings and grounds.

IVGID REQUIREMENTS FOR CONSTRUCTION OF WATER & SEWER

ARTICLE 2. WATER SERVICE LINE SPECIFICATIONS

2.01 Service Line Requirements for Two Inch (2") and Smaller: For each service line upgrade required per the UPC, each lot shall be serviced by a separate service connection of required size from the District main water line to the water meter. Fire service and domestic water service shall use the same main line water tap, with separation downstream of the water meter. The fire line shall continue through an iron body gate valve with a two inch (2") operating nut with an epoxy coated body and terminate at structure. The domestic water line shall be connected off a tee fitting downstream of water meter and upstream of fire gate valve. The domestic line shall continue through an iron body gate valve with a two inch (2") operating nut with an epoxy coated body and then through a curb stop and terminate at structure. See Combined Domestic and Fire Water Service Detail. The District requires that all approved piping must be installed through the foundation and capped for pressure testing. Domestic Water and Fire Water Piping must be cored through the foundation utilizing link seals. Speak to an IVGID inspector for installation criteria or call 775-832-1224 if installed under the foundation. SDR 35 and/or Ductile Iron piping must be used as a sleeve.

- A. IVGID jurisdiction extends up to and through the foundation on all water, fire and sewer services.
- B. For four inch (4") and larger applications, see Water Services for Metered Domestic and Detector Check Fire Water Services detail on Page 25. Four-inch (4") stainless steel risers shall be installed on all 4" and above lines, entering through the foundation of building need to be cord and link sealed. Other means of installation can be approved by the agent/inspector of the district.

2.02 Pipe Materials: Water service lines shall conform to the UPC and applicable AWWA standards and be Type K copper tubing or 200-250 PSI PE 4710 tubing, SDR-9 ASTM D-2737, SDR-11 D-3035 copper tube size. PVC C-900 DR14 Class 305 and Ductile Iron Pipe class 305 are allowable for services four inches (4") or larger. If copper is used, service lines two inches (2") in diameter or smaller shall be Type K copper conforming to ASTM B-88. Customer service valve boxes must be Christy G-5 or equivalent concrete box with a steel lid marked "Water." Line sizes are to be commensurate with health standards to ensure that no stagnant water will accumulate. All service line fittings shall be mechanical compression type, or soldered with lead free UPC approved solder. Solder spools shall be available for inspection.

From the District's main line to the meter, only mechanical joints will be allowed. Under no circumstances will pipe crimping or soldering be accepted by the District.

2.03 Curb Stops: Shall be non-stop and waste type and be approved by UL Listed and FM Approved lead free curb stops shall be installed no more than two feet (2') downstream of the water meter box/pit with an approved G-5 round concrete box with a steel lid marked water.

2.04 Air Relief Valve: Air relief valve shall be single-housing style, cast-iron body, stainless steel trim, one inch (1") inlet and outlet connections, and or 5/16" diameter orifice for a working maximum pressure of 300 psi. Contact the District at 775-832-1224 for Model and Installation Criteria.

2.05 Trenching: All trenching for water and sewer lines must meet OSHA requirements.

IVGID REQUIREMENTS FOR CONSTRUCTION OF WATER & SEWER

- 2.06 Separation:** All water lines shall be placed at and maintain a minimum depth of thirty-six inches (36") and be on an undisturbed shelf. All water utility lines, domestic and fire sprinkler systems must keep a twelve inch (12") separation at all times. All sewer service lines shall maintain at least twelve inches (12") vertical separation below the water line, and maintain a minimum horizontal separation of twelve inches (12") from water line at all times. If the sewer line is pressurized, the vertical separation is twelve inches (12") below the water line and the horizontal separation is five feet (5'), in a separate trench. Any other installation must be approved by IVGID Compliance. THIS IS AN IVGID REQUIREMENT.
- 2.07 Tracer Wire:** All pipe materials (except copper) require an approved #10 tracer wire attached to the pipe every five feet (5') by means of tape, and made accessible at the meter yoke.
- 2.08 Caution Tape:** Warning Tape shall be blue in color, three inches (3") in width, 5 mil in thickness, permanently printed "CAUTION: BURIED WATER LINE BELOW," installed twelve inches (12") above the pipe.
- 2.09 Bedding:** Material used for the pipe zone shall be sand, cinder, or Class A backfill with no mineral material larger than three eighths of an inch (3/8") as stated in Section 200, aggregate, of the Standard Specifications for Public Works Construction for Washoe County. The trench bottom shall be level and smooth, and excavated as needed to maintain a minimum of six inches (6") of bedding below the grade required by the underside of the pipe barrel, with twelve inches (12") above the pipe. Minimum allowable cover for water service lines is thirty-six inches (36").
- 2.10 Backfill:** All backfill shall meet the requirements of Class E backfill as stated in Section 200, Aggregate, of the Standard Specifications for Public Works Construction for Washoe County, with no rock larger than four inches (4"). If native material does not meet these requirements, backfill material shall be imported. Minimum allowable cover for water service lines is thirty six inches (36").
- 2.11 Main Line Tapping:** When making a new service connection to the District main line, all taps shall maintain a minimum of two feet (2') separation between all fittings, Joints and appurtenances. This applies to all main line pipe. Any other installation must be approved by the District.
- 2.12 Tapping Saddles and Tapping Sleeves:**

Tapping Saddles: For water services shall be epoxy coated ductile iron body with two stainless steel straps. Saddles shall be suitable for 250-psi service and torqued to manufacturers specifications.

Tapping Sleeves: Shall be Stainless Steel and shall be or equivalent for all taps larger than two inches (2") in size. Shall be torqued to all manufacturers specifications by means of a torque wrench.

All Tapping Sleeves: Shall be hydrostatically tested. The hydrostatic test pressure (No Air Testing Permitted) shall not exceed 1.25 psi times the pressure inside of the pipe being tapped at the time of the test. The testing time shall last for 15 minutes with no loss. Air testing of any tapping SLEEVE is prohibited. Torque all bolts to manufacturers specifications.

IVGID REQUIREMENTS FOR CONSTRUCTION OF WATER & SEWER

- 2.13 Cathodic Protection:** This is not required on any District-approved plastic piping. Installation of cathodic protection is required for all copper water services. A 5-pound "high potential" magnesium anode, packaged in chemical backfill with ten feet (10') of #12 lead wire, shall be used. The anode shall be buried at a minimum depth of forty-eight inches (48"). A bronze or brass clamp shall be used to attach the lead wire to the meter yoke. The anode must be a minimum of thirty-six inches (36") from the meter yoke, service line or water main. If a locating wire is installed on the water service line, cathodic protection shall be installed a minimum of once every five hundred feet (500') and at each intersection along that line.
- 2.14 Pressure Regulator and Isolation Valve:** At all, service locations, property owners are required to furnish individual lead free pressure regulators. All pressure regulators must be installed under house within ten feet (10') of access door, readily accessible, and approved by the District. If house is slab-built, the pressure regulator must be located in a readily accessible and District-approved location. An isolation valve is required directly upstream of the pressure regulator for service of the regulator and isolation of the structure's plumbing.
- 2.15 Water Pressure Testing:** The Contractor shall provide all labor, tools, and equipment necessary to perform required tests. Any faulty equipment shall be replaced before any test is accepted. Water lines four inches (4") and greater shall be tested/disinfected per the following: (Length x Pipe Diameter x Square root of pressure divided by 148,000.) All water lines smaller than four inch (4") will be tested at the District's main line pressure.
- 2.16 Water Pressure Testing time:** Minimum time frame of 1 hour of IVGID engineering may require a longer testing time, based on scope of work.

$$\text{Example: } L = \frac{SD (\text{square root of pressure}) (1000 \text{ lineal feet of } 6'' \text{ pipe tested at } 200\text{psi})}{148,000}$$

$$\text{Example} = \frac{1000' \times 6'' \times 13.41}{148,000} = 80,460 = .54 \text{ gallons}$$

$$32\text{oz.} = 1 \text{qt.} \quad 64 \text{oz.} = 2\text{qt.} \quad 96 \text{oz.} = 3\text{qt.} \quad 128\text{oz.} = 4\text{qt./1 gallon}$$

Chlorine Test: $\geq 50\text{ppm}/24\text{hr}$ $\geq 10\text{ppm}/\text{Flushing/residual}/\text{BACT-T-Testing}$.

2nd Option Test: $\geq 200\text{ppm}/3\text{hrs}$ $\geq 200\text{ppm}/\text{Flushing/residual}/\text{BACT-T-Testing}$.

Note: All BACT-T-Testing is a 24 Hr. testing timeline. (No Friday samples)

During the water pressure & disinfection testing all new water, piping must maintain an approved Air Gap from the IVGID potable water system. No physical water connection point(s) can be installed until all Back-T testing has approved by the district.

Service Line Test: After the meter is set, the water will be turned on and the line tested for leaks and proper installation. The service line shall be exposed at this time and all visible leaks shall be repaired. Once approved, the water service line may then be backfilled.

- 2.17 As-Built Plans:** Contractor is responsible to submit As-Built plans to the District upon completion of work. These utility plans/drawing must have 2 reference points taken from each end of building(s) for all water meter and shut off valves. For projects larger than a duplex, the district will require plans or drawing to be on a PDF file. Plans or drawings can be approved by the agent or inspector on a case by case bases.

IVGID REQUIREMENTS FOR CONSTRUCTION OF WATER & SEWER

Article 3. WATER METER SPECIFICATIONS

- 3.01 Meters:** All water meters are provided by IVGID. Contractor must survey said parcel property corner and install water meter and stake at the approved property corner. Other location of the water meter can be approved by an agent or inspector of the district.
- 3.02 Temporary Meter Sets:** A temporary meter may be set upon request. A temporary meter rental form must be completed and approved by a District compliance inspector.
- 3.03 Meter Setters:** Meter setters are required and, for ¾" and 1-inch services, shall be the Mueller Easy Setter Meter Pit with no bypass; for 1.5" and 2" services shall use the Mueller EZ Vault Meter Setter with no bypass. No coils will be permitted.
- 3.04 Meter Pits:** Meter pits for ¾" and 1" services shall be the Mueller EZ Setter Meter pit with no bypass; for 1.5" and 2" services shall use the Mueller EZ Vault Meter Setter with no bypass. NO COILED PITS ARE PERMITTED. The meter lid shall be a DFW18MUE-1MQF shall have a modified lid hook be non-locking and be marked "Water." Meter vaults for larger than two-inch (2") services must be approved by IVGID and accommodate all appurtenances and provide a 12" clearance on all sides within the boxes. The lid must be a steel spring-loaded bolt-down type. Meter installations shall be made at the property line, in the right-of-way (ROW). Meter locations to be marked with a BLUE stake.
- 3.05 Concrete Boxes:** G-5 Traffic Rated Boxes, F-8 Non Traffic Rated Boxes B-12, 16, 36 all can be approved with the approval of the agent or Inspector of the District.

ARTICLE 4. FIRE SYSTEM SPECIFICATIONS

- 4.01 Fire Service Requirements:** The North Lake Tahoe Fire Protection District will determine the size of connection required for fire service and adequacy of system for fire protection. Fire service taps will be made using the same materials and methods as stated herein for service taps. The District recognizes that the beginning point of the fire system shall be on the downstream side of the backflow prevention device. All backflow devices must be approved by the district and all discharges lines must be installed by the contractor and approved by the district.
- A. **Service Line Requirements, 2" and Smaller:** For each service line upgrade required per the UPC, each lot shall be serviced by a separate service connection of required size from the District main water line to the water meter. Fire service and domestic water service shall use the same main line water tap with separation downstream of the water meter. The fire line shall continue through an iron body gate valve with a two inch (2") operating nut with an epoxy coated body and terminate at structure. The domestic water line shall be connected off a tee fitting downstream of water meter and upstream of fire gate valve. The domestic line shall continue through an iron body gate valve with a two inch (2") operating nut with an epoxy coated body and then through a curb stop and terminate at structure. Please see diagram Combined Domestic and Fire Water Service detail or contact the IVGID Utilities Department at 775-832-1224 for more information. The District requires that all approved piping must be installed to within five feet (5') of foundation and capped for pressure testing.

IVGID REQUIREMENTS FOR CONSTRUCTION OF WATER & SEWER

- B. **Fire Service Line Requirements, 4" and Larger:** All fire systems requiring a 4" or larger pipe size must install a single-check detector, IVGID approved 250 PSI piping and one-piece stainless steel riser with anchorage (see Detail Page 26). All 4" or larger fire systems must be chlorinated/disinfected to IVGID specifications and/or Nevada state codes and regulations. All chlorination/disinfection must be witnessed and lab tested by IVGID **before any physical water connection point(s) can be made to the IVGID potable water system.**

- 4.02 Automatic Sprinkler System Design Criteria Design:** The criteria for automatic systems can be found in the most current adopted editions of the National Fire Protection Association (NFPA) Standard 13 and NFPA Standard 13R with amendments (13D is not acceptable). A minimum 10-psi margin between the available water supply and the system demand point, including any required inside hose stream allowance, is required by NAC 477.465. (Customary margin allowance of only ten percent (10%) common in other regions is not allowed by this Nevada Fire Marshal regulation).

Notes

- All single-family dwellings larger than 10,000 square feet or more than four (4) stories in height must conform to the design requirements in NFPA 13 (IFC 903.3.1.1).
- A "modified" 13R System may be considered for remodel projects less than 10,000 square feet (modified 13R systems can be requested and will be reviewed on a case-by-case basis by the NLFPD Fire Prevention.
- Designers of the fire sprinkler systems must hold a minimum Level II certification from the National Institute for Certification in Engineering Technologies (NICET) be licensed as a professional engineer pursuant to Chapter 625 of NRS.

- 4.03 Separation:** All fire sprinkler systems must be separated from the District water system with an approved backflow prevention device. This device must be approved by the District and in compliance with all State and Local codes.

- A. Double Check backflow prevention devices shall be approved for class one (1), two (2), three (3) or four (4) fire systems when chemical additives are not being used. When a Double Check backflow prevention device has approval from the District to be installed on class one (1), two (2), three (3), or four (4) fire systems the installation must meet all State and local codes. The District also requires a sign to be placed in an approved location, with two inch (2") red letters on a white background stating the class of system, water only, absolutely no additives of any kind.
- B. Reduced pressure backflow prevention devices shall be approved for class four (4), five (5) or six (6) fire systems when chemical additives are being used. The installation must meet all State and local codes.

ARTICLE 5. DISTRICT REGULATIONS FOR BOILER/MECHANICAL SYSTEMS

- 5.01 Boiler Backflow:** All boiler/mechanical systems must be separated from the District water system with an approved reduced pressure backflow prevention device or an approved air gap. It must be installed in compliance with all State and local codes, and must be plumbed from a domestic cold

IVGID REQUIREMENTS FOR CONSTRUCTION OF WATER & SEWER

water supply only. All backflow reduced pressure assembly backflow devices, discharge lines must be installed by the contractor and approved by the district. Boilers with a self contained unit inspected and approved by IVGID do not need an approved backflow device.

- 5.02 Heat Exchangers:** All heat exchangers used for domestic hot water service must be double walled.
- 5.03 Hot Water Tanks:** All boilers that heat a hot water tank must be equipped with a double walled heat exchanger.

ARTICLE 6. DISTRICT REGULATIONS FOR IRRIGATION SYSTEMS

- 6.01 Irrigation Requirements:** All irrigation systems require a Washoe County Irrigation permit for construction. All work must comply with the District landscape packet.
- 6.02 Separation:** All irrigation/sprinkler systems must be separated from the District water system with an approved backflow prevention device installed to all State and local codes.
- 6.03 Irrigation Materials:** Materials shall comply with the District specifications as type K copper or brass. All fittings must be approved curb stops, Drain Valves and unions for winter time removal. Devices shall be plumbed so no water shall be in standpipes when device is removed for winter time.
- 6.04 Inspections:** All inspections of connections to the domestic water line is required, please call IVGID Compliance at 775-832-1224 to schedule an appointment. On-site inspection prior to installation is highly recommended, to assure compliance with District regulations.

ARTICLE 7. REGULATIONS FOR PRIVATE BACKFLOW TESTING

- 7.01 Forms:** All IVGID backflow-testing forms must be properly filled out. All testing forms must be submitted to the District within two (2) working days from the date of the test. Compliance@IVGID.org
- 7.02 Testers:** All testers must be licensed with the American Water Works Association (AWWA).
- 7.03 Device Certification:** Any backflow device that does not pass the initial certification test must be repaired and retested. If repairs require delay due to parts, etc., the District will allow five (5) additional working days for such repairs and retest. If a repair & retest require longer than the five (5) working days, an additional extension must be approved by the District.
- 7.04 Compliance:** Failure to comply with 7.01 or 7.02 will result in the tester's name being given to the Northern Nevada Backflow Administrator for AWWA.
- 7.05 License/Calibration:** Proof of current AWWA license and approved annual gauge calibration must be submitted to the District with every test or group of tests. These may be emailed to compliance@ivgid.org hand delivered or mailed.

ARTICLE 8. SEWER SERVICE SPECIFICATIONS

- 8.01 Materials:** Acceptable pipe materials are DUCTILE IRON or POLYVINYL CHLORIDE PIPE SDR 35, all of which shall conform to the specifications set forth in the UPC. Joints shall be of the same material as

IVGID REQUIREMENTS FOR CONSTRUCTION OF WATER & SEWER

the pipe using internal rubber or plastic gaskets, or an external rubber sleeve using stainless steel bands, all as manufactured strictly for use with particular type of pipe. Solvent weld joints, ABS Piping, Brass or Copper shall not be permitted. Where different pipe materials are jointed the connection shall be made by the use of an approved mechanical coupling specifically manufactured for use with the different pipes to be joined. Fittings such as Max adaptor couplings or coupling approved by the district agents shall be approved. POLYVINYL CHLORIDE PIPE shall not be used where the cover is less than thirty-six inches (36") or greater than eighty-six inches (86"). DUCTILE IRON may be used when eighteen inches (18") of cover is available. For shallower depths, concrete encasement or other special means approved by the District must be used to protect the pipe.

- 8.02** **Size:** Building sewer shall be a minimum diameter of four inches (4") or six inches (6") for single family residences. Building sewers for apartments, motels, and commercial establishments shall be sized in accordance with the requirements of the UPC and shall be four-inch (4") minimum size.
- 8.03** **Trenching:** All trenching for water and sewer lines must meet OSHA Requirements.
- 8.04** **Separation:** All water lines shall be placed at and maintain a minimum depth of thirty six inches (36") and be on an undisturbed shelf. All sewer service lines shall maintain at least 12 inches (12") vertical separation below the water line, and maintain a minimum horizontal separation of twelve inches (12") from water line at all times. If the sewer line is pressurized than the vertical, separation is twelve inches (12") below the water line and the horizontal separation is five feet (5') in a separate trench. Any other installation must be approved by IVGID Compliance. **THIS IS AN IVGID REQUIREMENT.**
- 8.05** **Building Sewer Construction:** Where building sewer main line connections have not been provided by the District to the property, and/or the properties were not assessed for the building sewer installation, the property Owner shall assume the cost of providing the required connection. Owner shall be responsible for obtaining the necessary Washoe County street-cut permits and coordination with other utility agencies for their utility locations. Owner requesting the tap will be responsible for cutting pavement and excavating the trench to proper depth and grade. Owner shall be responsible for the tap to the main. Owner is responsible for laying building sewer with all required appurtenances.
- 8.06** **Connection to the existing Sewer Main:** Shall be with an approved Romac style "CB" or equivalent double stainless steel strap saddle for transite, plastic, cast iron, or concrete mains. A Fernco Flexible tapping saddle with Part A and B epoxy may be approved. For vitreous clay main, a section must be removed and a wye installed with Romac style couplers or other approved by IVGID. The pipe grade for four inch (4") must be two percent (2%) grade or a minimum of 1/4" per foot of fall or greater. Six inch (6") diameter pipe must be one percent (1%) grade or a minimum of 1/8" per foot of fall or greater. The District requires that all approved piping must be installed within five feet (5') of foundation and capped for pressure testing.
- 8.07** **Tracer Wire:** All pipe materials, except copper, require an approved #10 tracer wire attached to the pipe every five feet (5') by means of tape or other approved means, made accessible at the clean-outs.

IVGID REQUIREMENTS FOR CONSTRUCTION OF WATER & SEWER

8.08 Caution Tape: Warning Tape shall be green in color, three inches (3") in width, 5 mil in thickness, permanently printed "CAUTION: BURIED SEWER LINE BELOW," and installed twelve inches (12") above the pipe.

8.09 Water/Air Testing: Contractor shall provide all labor, tools, and equipment necessary to perform the required tests. Any faulty equipment shall be replaced before any test is accepted. Contractor shall supply a pressure gauge that can be read in increments of between one and five psi, in accordance with the UPC. Installation must pass the standard five pounds per square inch (5 psi) for fifteen (15) minute pressure tests, per the UPC. Mandrel/Ball/Flush testing will be required on all new sewer piping. Mandrels shall be specifically designed for the piping being tested. This testing is typical of 4" and larger piping.

Manholes shall be tested with the ring, cover and grade adjustment rings installed. All pipes entering the manhole shall be plugged and braced and a vacuum of ten inches (10") of mercury shall be drawn. The vacuum pump shall be turned off and the time monitored as the vacuum drops one inch (1"). The vacuum must not drop more than one inch (1") for the duration of the time indicated in the following table:

Diameter	Time	Mercury Level	Allowable Loss
48 Inches	1 Minute	10 Inches	1 Inch max.
60 Inches	1 Min. 15 Sec.	10 Inches	1 Inch max.
72 Inches	1 Min. 30 Sec.	10 Inches	1 Inch max.

Manholes which fail the vacuum test shall have the defects located and repaired and the test shall be repeated. Repair and repeat testing shall be continued until the testing requirements are met.

8.10 As-Built Plans: Contractor is responsible to submit As-Built plans to the District upon completion of work. These plans must be on a PDF file for any project larger than a Triplex. Smaller projects may be submitted on an 8.5" X 11" sheet of paper. These will be reviewed and approved by the District.

8.11 Bedding: Material used for the pipe zone shall be sand, cinder, or Class A backfill with no mineral material larger than three eighths of an inch (3/8") as stated in Section 200, aggregate, of the Standard Specifications for Public Works Construction for Washoe County. The bottom of trench shall be level and smooth, and excavated as needed to maintain a minimum of six inches (6") of bedding below the grade required by the underside of the pipe barrel, with twelve inches (12") above the pipe. Minimum allowable cover for sewer service lines is twelve inches (12").

8.12 Backfill: All backfill shall meet the requirements of Class E backfill as stated in Section 200, Aggregate, of the Standard Specifications for Public Works Construction for Washoe County, with no rock larger than four inches (4"). If native material does not meet the requirements then backfill material shall be imported. Minimum allowable cover for sewer service lines is twelve inches (12").

8.13 Clean-Outs: A clean out shall be provided by the Owner within five feet (5') outside of the foundation. A clean out must also be installed where the building sewer crosses the property or easement line. All clean-outs shall be installed at intervals not to exceed one hundred feet (100'); variances in this length must be approved by IVGID Compliance. In a change of direction ninety degrees (90°) or more, a clean-out must be installed within one foot (1') of that transition. All clean-outs shall be cut to grade, plugged, and have a concrete box with metal lid marked "Sewer." Plugs shall be two piece expansion

IVGID REQUIREMENTS FOR CONSTRUCTION OF WATER & SEWER

types similar to ETCO, T-cone stopper or equivalent steel or alloy is prohibited. Owner shall be responsible for keeping clean-out boxes from being buried or damaged.

- 8.14 Backwater Valves:** Installation of a backwater valve on lots with fixtures lower than the next upstream manhole, as more specifically explained in the UPC, shall be enforced. Backwater valves must be installed in an accessible location inside or outside of the structure. Outside installations will be required to be properly boxed, upstream of foundation cleanout. Please see the following Backwater Valve Diagram for a further explanation. Combination Backwater/Cleanouts may also be utilized call The IVGID Compliance Dept. 775-832-1224 for further details and installation criteria.
- 8.15 Max Adaptor Coupling:** Max adaptor the universal shielded sewage coupling for non-pressure sewer coupling for 4" 6" 8" 10" the 10" coupling with cover the 12" SDR range sewer piping.
- 8.16 Link Seals:** Shall be used on all penetrations of Vaults and Foundations.

IVGID REQUIREMENTS FOR CONSTRUCTION OF WATER & SEWER

BACKWATER VALVE DIAGRAM

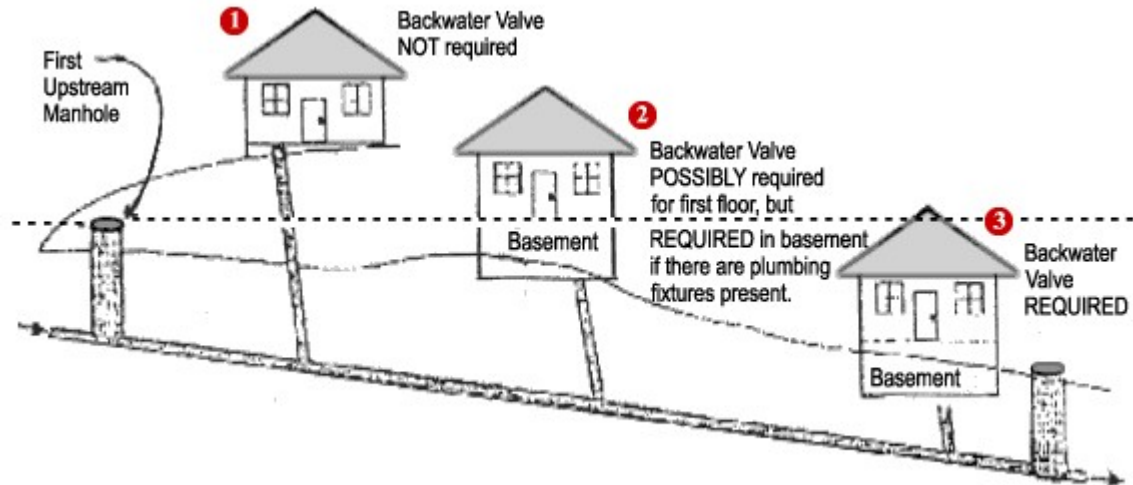

One of the keys to preventing a sewer backup in your basement is knowing your location in relation to the sanitary sewer system that serves your building or home. A sewer backup valve (backwater valve) can make all the difference between having your basement or home flooded knee deep with raw sewage and staying high and dry.

- **Home #1** does not need a backwater valve because water would drain from the first upstream sanitary sewer manhole which is lower than the inlet to the drain pipe in this home's basement. This home should not experience a flooded basement due to a sewer backup.
- Drains located on the first floor of **Home #2** might be safe as it is slightly higher (must be at least 24" higher) than the first upstream sanitary sewer manhole cover, but there are some cases in which pressure builds enough to temporarily allow water to flow at a level above the lowest drain. When in doubt, and especially when the second floor living space is installed, it is wise to install a backwater valve. However, any drain fixture in the basement of Home #2 would be below the level of the first upstream manhole and sewage backups could occur without a backwater valve.
- Any drain opening in **Home #3** would be located below the level of the first upstream sewer manhole cover so this home would definitely require the installation of a backwater valve.

All Backwater Valves shall be placed within the crawl space or confines of the home and be made readily accessible for maintenance and repairs. Exceptions can be made if the home is slab built.

Please contact IVGID Compliance 775-832-1224 for more details.

IVGID REQUIREMENTS FOR CONSTRUCTION OF WATER & SEWER

8.17 Grease Interceptor, Interceptor and Separator Installation Requirements and Test Procedure:

- A. Grease interceptors, interceptors and separators shall be required when and where necessary for the removal of grease, oil, sand, garbage, flammable wastes or other waste components not typically present in wastewater. No such device shall be required for residential service. Grease interceptors, interceptors and separators and sampling pits shall be constructed to prevent any bypass of matter prohibited in the wastewater system.
- (1) **Grease Interceptors.** Grease interceptors shall be installed for establishments where food is prepared or other establishments where grease is introduced into the drainage or sewage system in quantities that can effect sewer mains, effect wastewater treatment or have other negative impacts on the sewer system.
- Grease interceptor Plan Requirements: Plans submitted to the Washoe County Building Department for permitting grease interceptors shall include the following:
 - a) The design, operation and sizing of all interceptors shall be performed by a licensed engineer using the formula from the most recent District-adopted UPC, as specified in Appendix H, Section H 901.0.
 - b) No food waste disposal unit or dishwasher shall be connected to or discharge into any interceptor unless specifically designed for this function.
 - c) Make, model, and size of unit to be constructed.
 - d) Location of unit to be constructed. Interceptor shall be located as close to the source as possible and be accessible for servicing and sampling.
 - e) A sampling box shall be installed downstream of all grease interceptors.
 - f) A sewage backwater valve shall be installed immediately downstream of the sample box prior to connection with the building sanitary sewer.
 - g) Hydromechanical grease interceptors are not permitted.
 - h) Toilets, urinals and other similar fixtures shall not drain through an interceptor.
- (2) **Interceptors (Clarifiers) and Separators.** Interceptors and clarifiers shall be required for the proper handling of liquid wastes containing flammable wastes, sand, solids, oil, acid substances or alkaline substances or other ingredients harmful to the building. The design of these interceptors and separators shall be performed by a licensed engineer using the formula from the most recent District-adopted UPC, as specified in Appendix H, Section H 901.0. These types of interceptors are typically installed for auto repair facilities, car washes, warehouses and other similar facilities. For food establishments, see Grease Interceptor section, above.

IVGID REQUIREMENTS FOR CONSTRUCTION OF WATER & SEWER

B. **Setting and Installation:** The grease interceptor, interceptor and/or separator shall be constructed following the Manufacturer's installation procedures, including accessibility, setting unit on level base, installing inlet and outlet pipes, inlet vented flow control(s), vents, grouting, sealing, setting and adjusting of grade rings, risers, frames, covers and all other hardware and appurtenances and sampling structures.

8.18 Water Testing Policy and Procedure: The Trap/Interceptor/Separator shall be tested to insure that the system as a whole is watertight. The unit is designed to be watertight so the Trap/Interceptor/Separator shall be filled with water to the cover frame and hold water with no measurable loss for a period of sixty (60) minutes. Concrete units will be allowed time for complete adsorption within unit, and then be refilled for the sixty (60) minute test. Watertight testing must be completed and approved after installation and before the Trap/Interceptor/Separator is put into service.

8.19 Trap/Interceptor/Separator Final Inspection: A final inspection shall be made of the unit before the Washoe County Building Permit is signed off by IVGID. The Trap/Interceptor/Separator shall be accessible, have accessible vented flow control(s), sealed covers, and be connected to all required fixtures ready for service. At the approved final inspection IVGID will issue a Commercial Wastewater Discharge Permit and authorize the unit to be put into service. IVGID will also issue a Customer Information Packet explaining the District policy on use, maintenance, and record keeping.

ARTICLE 9. INDIVIDUAL SEWER PUMP STATIONS

9.01 General: If an individual sewage pump station is to be installed outside of the foundation, it falls within the jurisdiction of the District and will be constructed to meet the following specifications. Individual sewage pump stations shall not be used in the District unless the property is too low to be served by gravity to an existing sewer line, the property owner shall install an individual pump station as approved by the District. The property owner shall install the pressure building sewer with his own contractor or employees. However, the District will approve materials and inspect and approve the construction. All pump stations will discharge into a manhole unless otherwise specified by the District. Where individual sewage pump stations are authorized, they shall be designed, constructed, and maintained in conformance with these specifications. District inspection of newly installed pumping facilities shall be completed in accordance with the procedures outlined within this document.

9.02 The District may periodically inspect any individual sewage pump station to determine if it is being properly maintained. Where stations are not being maintained in conformance with these specifications, service may be terminated. Resumption of service will not be allowed until all discrepancies are corrected and the District has approved the work. Any expense incurred by the District to discontinue and resume service shall be paid by the property owner at the time of reconnection.

9.03 Materials: Unless previously accepted in writing by the District, pressurized pipe from individual sewer pump stations shall be engineered size to provide a minimum velocity of (2') two feet per second, and not less than (2") in diameter. Piping approved by the District is Ring-Tite Class 200 PSI SDR 21 or Iron pipe size (IPS) class 200PSI PE3408/PE4710 tubing SDR11 ASTM D-2737. The 2" discharge piping connection to the pressurized line from the pump station shall be made with only

IVGID REQUIREMENTS FOR CONSTRUCTION OF WATER & SEWER

the IVGID approved fittings for the 2" IPS PE 3408/PE4710. **Solvent welded joints or brass fittings shall not be used.**

- 9.04 Connection Points to IVGID from Sewer lift Stations:** The sewer discharge piping from the lift station shall be 2" HDPE SDR11 piping installed with tracer wire and connected to a 4" SDR 35 gravity sewer clean out by means of a link seal. If the discharge piping is going to be connected, directly to a sewer manhole the manhole must be cored and link sealed. All piping must be fastened to the interior walls of the manhole with approved stainless steel connections or methods approved by the district. All piping and its fittings must allow the discharge flow to match the flow line within the sewer manhole.
- 9.05 Pumps:** A minimum of two pumps shall be provided at each individual sewage pump station. Where pumps are used, they shall be either grinder pumps or non-clog sewage pumps (dual compressor pneumatic ejector shall be utilized only with prior approval by the District) engineered to serve the dwelling and overcome the head pressure within the pressure ejector line.
- 9.06 Valves:** Each pump shall be equipped with a check valve and an isolating gate or ball valve. Valves and check shall be located in the dry chamber area outside of the actually wet well area so repairs can be completed.
- 9.07 Controls and Alarm:** Pumps shall be automatically controlled by the level in the wet well. The lag pump shall be controlled in such a manner that it will automatically take the place of the lead pump in the event of failure. An alternating system shall be installed to balance wear on both pumps. An audible alarm and a red high water level light shall be installed in a moisture proof enclosure adjacent to the station. This light must be visible from the street in public view and approved by the District. This light shall be controlled by a separate level setting above the lag pump control range. Red high water level light can be eliminated if high wet well alarm is monitored by a Security/Monitoring System.
- 9.08 Wet Wells and Storage Chambers:** A minimum of three hundred (300) gallons of storage per living unit shall be provided above the normal pump operation level, variances in storage capacity must be approved by IVGID Compliance. Such storage shall be provided either in the wet well or in an adjacent structure with a drain back feature. Storage is provided primarily to allow continued use during brief outages. Wet wells and storage chambers shall be concrete, polyethylene, or fiberglass. A manhole opening shall be provided into wet wells and storage chambers. The wet well shall be equipped with the required inlets and outlets.
- 9.09 Sewage Pump Station Vault:** An acceptable weather proof, insulated box with adequate waterproof insulation below the box lid directly above the holding tank. The outside bottom of the Sewage Pump Station Vault Tank must be anchored down by means of concrete. Concrete to be installed around the outside bottom of tank to prevent the Sewage Pump Station Tank from floating.
- 9.10 Testing:** Pressurized sewer pipe shall be hydrostatically tested for fifteen minutes (15) at 1.5 times the pump capacity or meet sewer pipe class specifications. Installation standard shall be manufacturer's specifications and shall meet all of the District's installation requirements. Wet well shall be hydrostatically tested for sixty minutes (60) with no loss. All functions of the station will be tested and approved by the District.

IVGID REQUIREMENTS FOR CONSTRUCTION OF WATER & SEWER

ARTICLE 10. COMMUNAL UTILITY SYSTEM SPECIFICATIONS

All communal utility water system specifications must comply to all information provided within this document of specifications. Its encouraged to contact the IVGID compliance Division at 775-832-1246 and schedule a meeting to discuss your project as your project could have additional requirements for the water and sanitary sewer systems.

ARTICLE 11. JOINT TRENCHING SPECIFICATIONS

- 11.01** Joint trenching of utility service lines is allowed; however, jurisdictional standards must be met within the public right-of-way and District easements. All water service(s) shall be installed and maintain a minimum of one foot (1') above and one foot (1') horizontally away from all building sewer on undisturbed soil/shelved. Complying with all current uniform plumbing codes rules and regulations.
- 11.02** All water services lines in joint trenching shall maintain a twelve inch (12") minimum separation at all times and have their own #10 tracer wire attached to the water service line every five feet (5') by means of tape.
- 11.03** Water mains constructed within the public right-of-way and District easements shall be installed twelve inches (12") minimum above the sewer main and a minimum of ten feet (10') horizontally away from the sewer where possible.
- 11.04** Joint trenching is not allowed with the District main systems.

No other utilities shall be installed within three feet (3') horizontally of the District main lines and/or within one foot (1') from service building sewers.

**** OTHER UTILITY AGENCIES MAY HAVE DIFFERENT SEPARATION CRITERIA. PLEASE CHECK WITH ALL AGENCIES PRIOR TO JOINT TRENCHING.**

ARTICLE 12. IVGID APPROVED INSTALLATION DETAILS

The construction details shown below were provide by IVGID to help you understand what is needed for your project to pass the required field inspections being performed by the Incline Village General Improvement District Compliance Inspector(s).

IVGID REQUIREMENTS FOR CONSTRUCTION OF WATER & SEWER

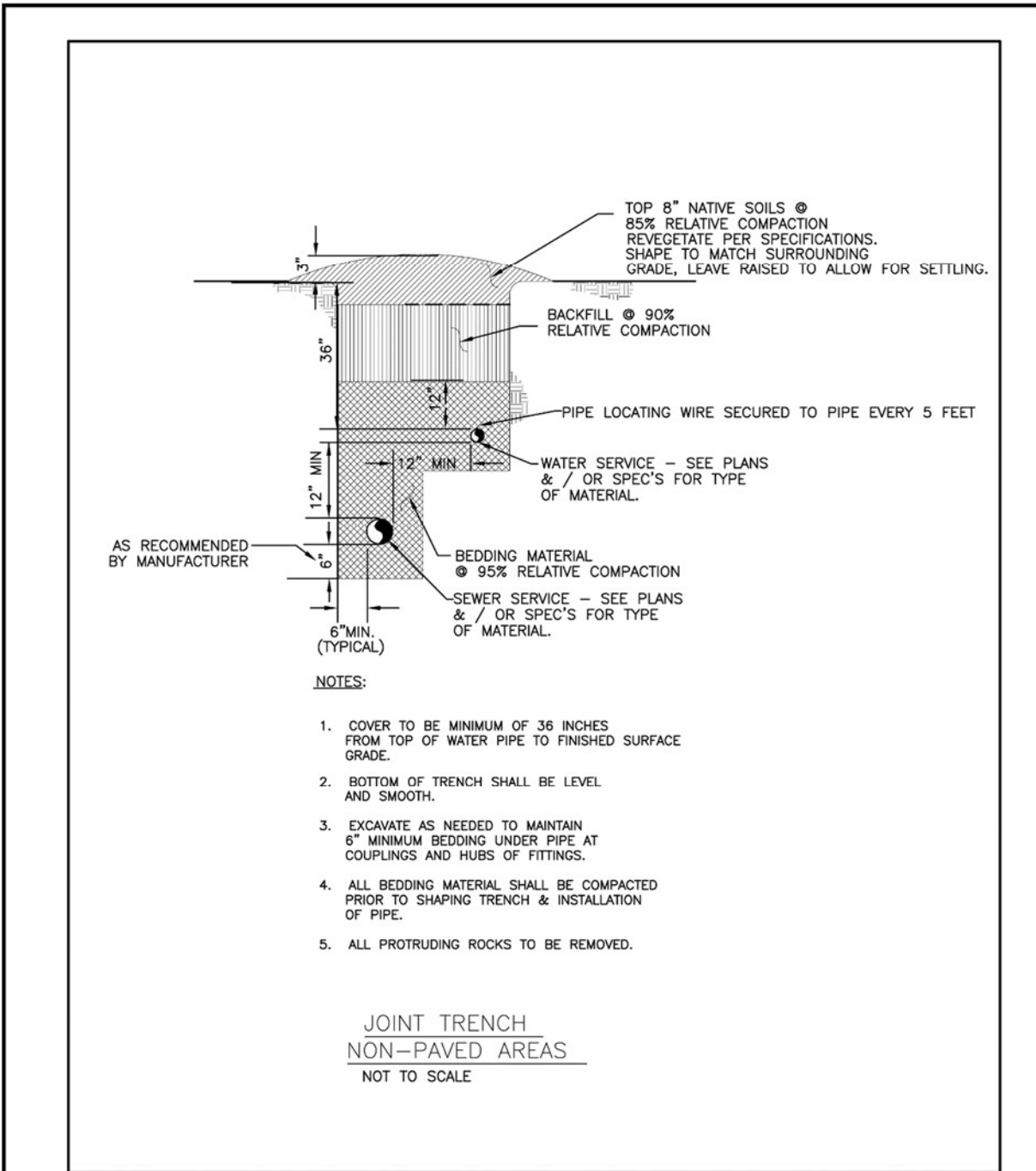

NOTES:

1. COVER TO BE MINIMUM OF 36 INCHES FROM TOP OF WATER PIPE TO FINISHED SURFACE GRADE.
2. BOTTOM OF TRENCH SHALL BE LEVEL AND SMOOTH.
3. EXCAVATE AS NEEDED TO MAINTAIN 6" MINIMUM BEDDING UNDER PIPE AT COUPLINGS AND HUBS OF FITTINGS.
4. ALL BEDDING MATERIAL SHALL BE COMPACTED PRIOR TO SHAPING TRENCH & INSTALLATION OF PIPE.
5. ALL PROTRUDING ROCKS TO BE REMOVED.

Project No. _____ DATE: 15 DEC 2014 SCALE: N.I.S. DRAWN: MTL DESIGN: APPROVED: _____ DATE: _____	INCLINE VILLAGE GENERAL IMPROVEMENT DISTRICT 1220 Sweetwater Rd.; Incline Village, Nevada 89451 Phone 775-832-1267 JOINT WATER/SEWER SERVICE DETAIL	
--	---	---

IVGID REQUIREMENTS FOR CONSTRUCTION OF WATER & SEWER

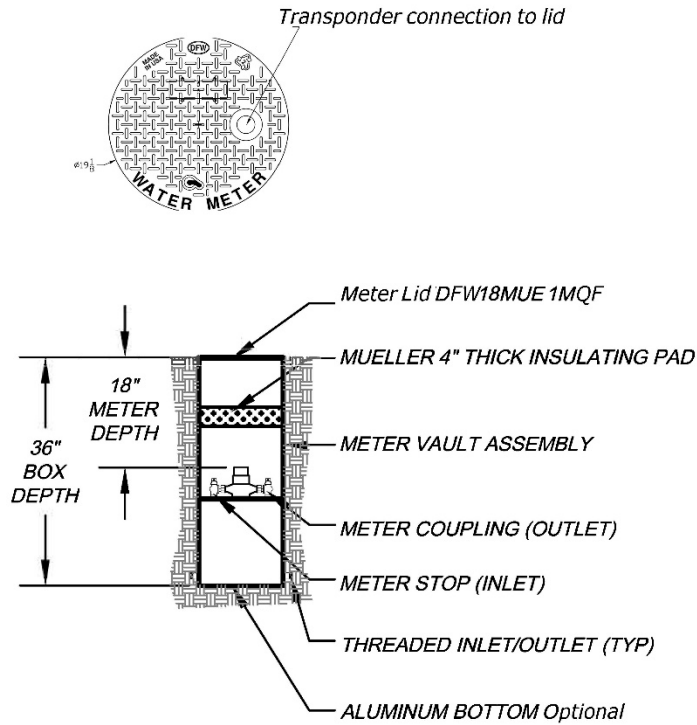

METER VAULT ASSEMBLY:

3/4" AND 1" METER - Mueller EZ Vault Meter setter with no Bypass

1.5" AND 2" METER - MUELLER EZ-VAULT METER SETTER (WITH NO BYPASS)

IVGID may except other products as approved by District Engineering Manager

Project No. _____ DATE: 15 MAY 2012 SCALE: N.T.S. DRAWN: MIL DESGN: MIL APPROVED: _____ DATE: _____	<b style="font-size: 1.2em;">INCLINE VILLAGE GENERAL IMPROVEMENT DISTRICT 1220 Sweetwater Rd.; Incline Village, Nevada 89451 Phone 775-832-1267 <b style="font-size: 1.1em;">METER PIT FOR NON-TRAFFIC AREAS	
---	--	---

IVGID REQUIREMENTS FOR CONSTRUCTION OF WATER & SEWER

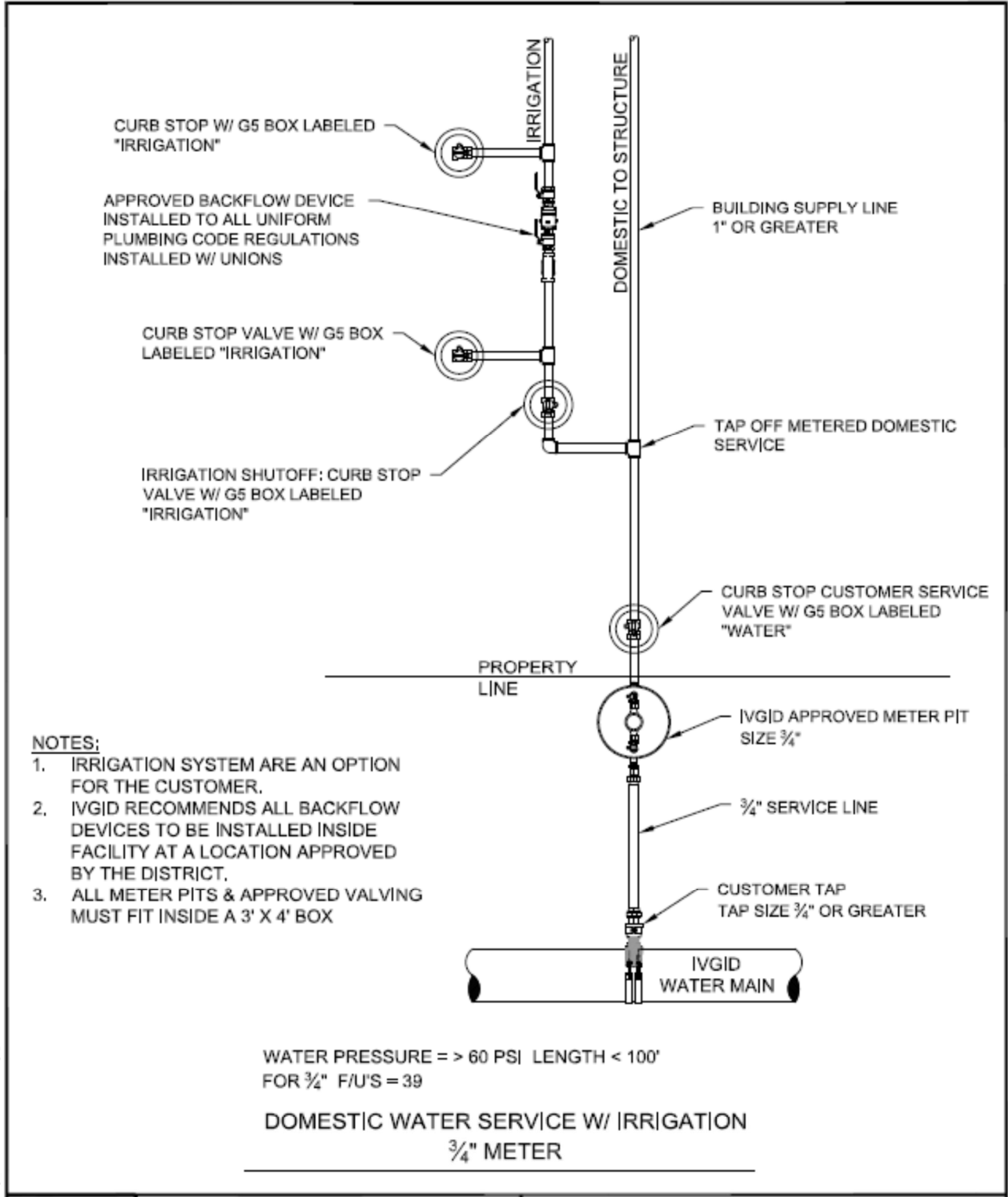

NOTES:

1. IRRIGATION SYSTEM ARE AN OPTION FOR THE CUSTOMER.
2. IVGID RECOMMENDS ALL BACKFLOW DEVICES TO BE INSTALLED INSIDE FACILITY AT A LOCATION APPROVED BY THE DISTRICT.
3. ALL METER PITS & APPROVED VALVING MUST FIT INSIDE A 3' X 4' BOX

WATER PRESSURE => 60 PSI LENGTH < 100'
FOR 3/4" F/U'S = 39

IVGID Compliance Division, 2021, 12/8/22, 12/8/22, 12/8/22, 12/8/22

PROJECT	STD DETAILS				
SCALE	NTS				
DATE	12/8/22				
SHEET	1	Dsgn	DWC	CHK	APPD BY:

DOMESTIC WATER SERVICE WITH IRRIGATION
3/4" METER

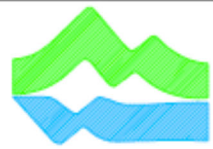

**INCLINE VILLAGE
GENERAL IMPROVEMENT
DISTRICT**

1220 SWEETWATER RD.
INCLINE VILLAGE, NV 89431
P. 877.468.4397

IVGID REQUIREMENTS FOR CONSTRUCTION OF WATER & SEWER

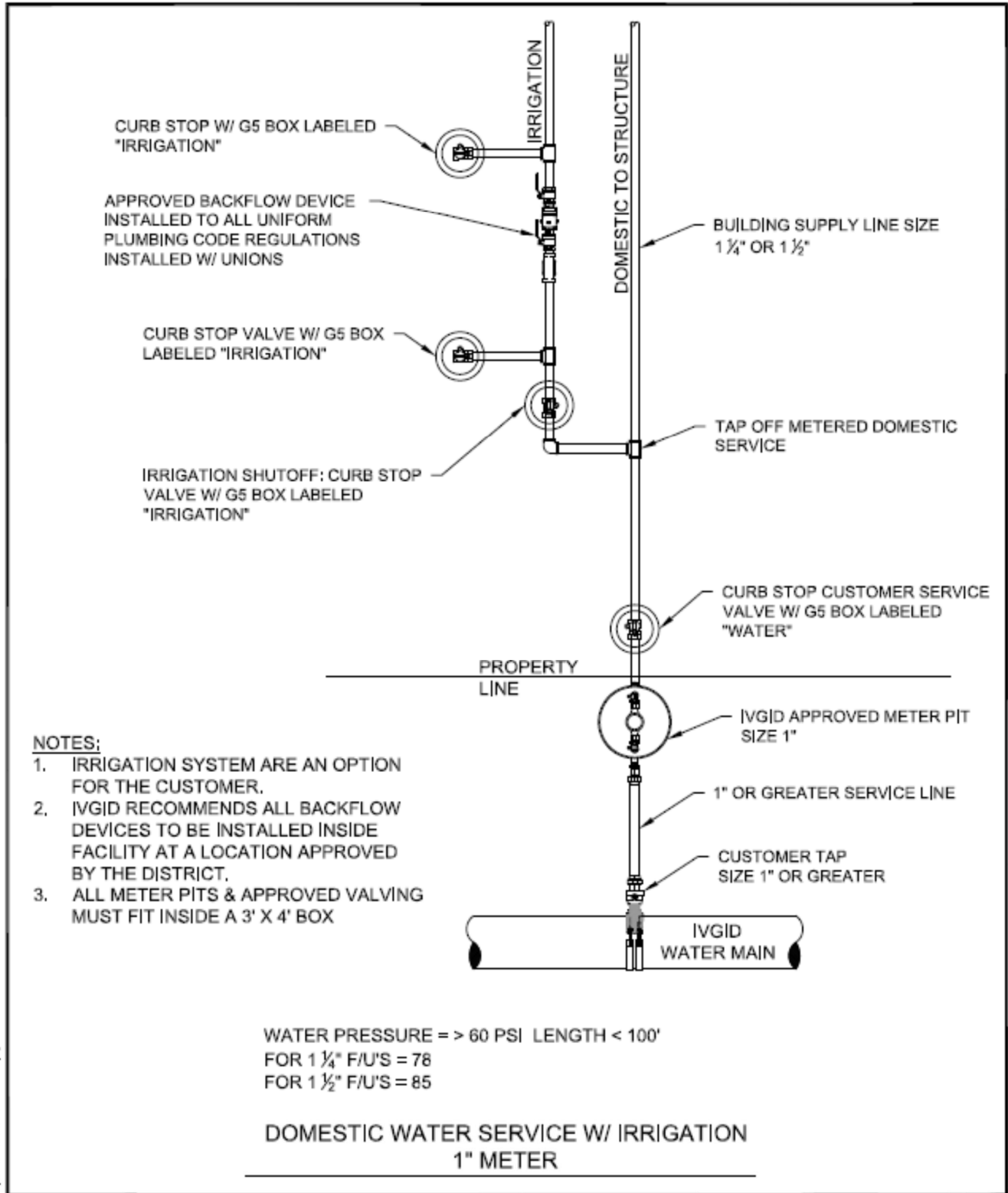

- NOTES:**
1. IRRIGATION SYSTEM ARE AN OPTION FOR THE CUSTOMER.
 2. IVGID RECOMMENDS ALL BACKFLOW DEVICES TO BE INSTALLED INSIDE FACILITY AT A LOCATION APPROVED BY THE DISTRICT.
 3. ALL METER PITS & APPROVED VALVING MUST FIT INSIDE A 3' X 4' BOX

WATER PRESSURE = > 60 PSI LENGTH < 100'
 FOR 1 1/4" F/U'S = 78
 FOR 1 1/2" F/U'S = 85

PROJECT	DOMESTIC WATER SERVICE WITH IRRIGATION			
STD DETAILS	1" METER			
SCALE	NTS			
DATE	12/8/22			
SHEET	DSGN	DWG	CHK	APP'D BY:
1				

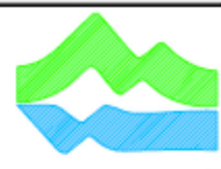

**INCLINE VILLAGE
GENERAL IMPROVEMENT
DISTRICT**
 1220 SWEETWATER RD.
 INCLINE VILLAGE, NV 89431
 P: 877.468.4307

IVGID REQUIREMENTS FOR CONSTRUCTION OF WATER & SEWER

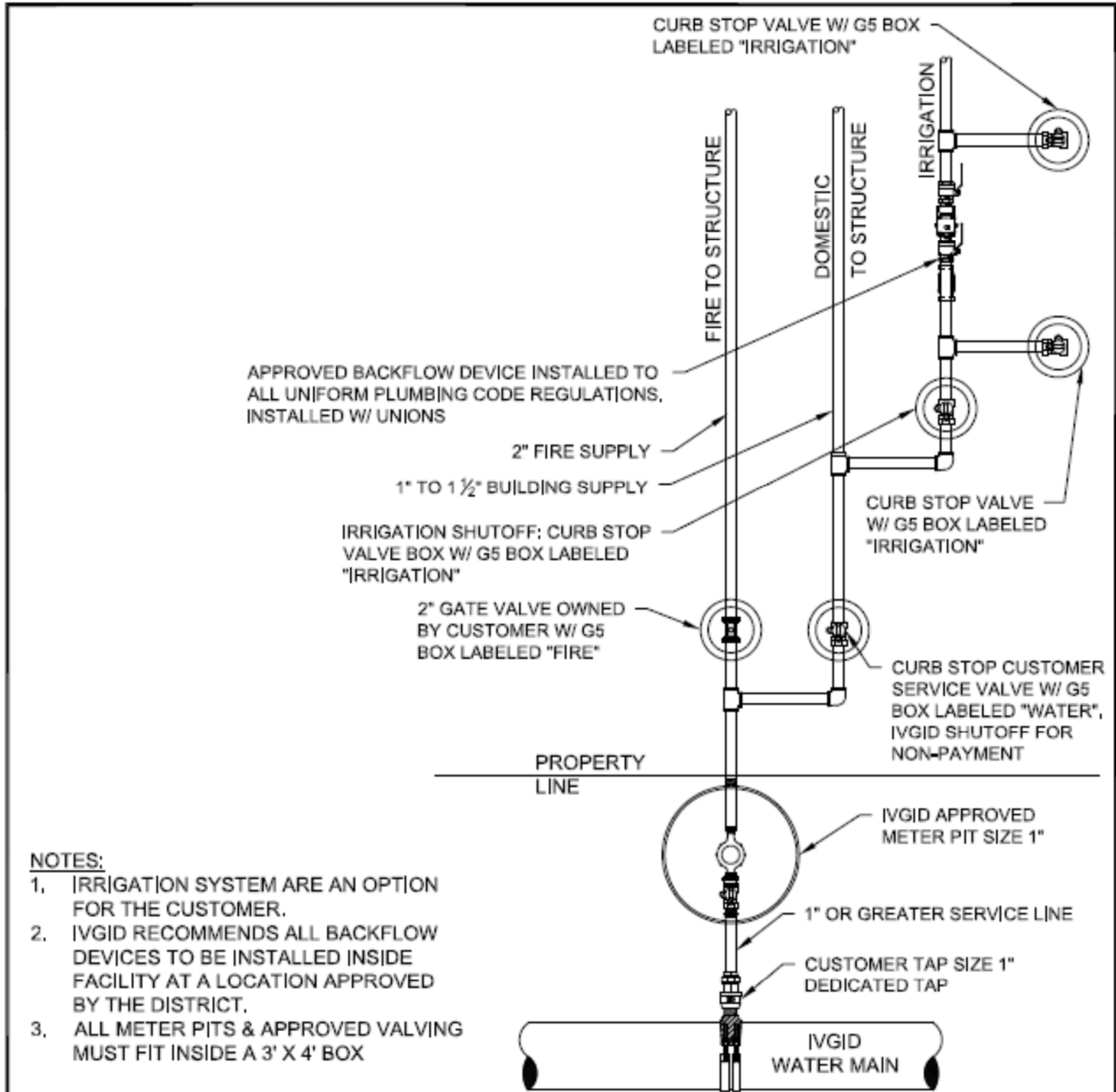

- NOTES:**
1. IRRIGATION SYSTEM ARE AN OPTION FOR THE CUSTOMER.
 2. IVGID RECOMMENDS ALL BACKFLOW DEVICES TO BE INSTALLED INSIDE FACILITY AT A LOCATION APPROVED BY THE DISTRICT.
 3. ALL METER PITS & APPROVED VALVING MUST FIT INSIDE A 3' X 4' BOX

WATER PRESSURE = > 60 PSI LENGTH < 100'
 FOR 1" F/U'S = 39
 FOR 1 1/2" F/U'S = 85

**DOMESTIC WATER SERVICE W/ IRRIGATION
 MODIFIED R-13 FIRE 2 HEAD FLOW CALC**

PROJECT	STD DETAILS				<p style="text-align: center; margin-top: 10px;">INCLINE VILLAGE GENERAL IMPROVEMENT DISTRICT</p> <p style="text-align: center; font-size: small;">1220 SWEETWATER RD. INCLINE VILLAGE, NV 89431 P: 877.468.4307</p>
SCALE	NTS				
DATE	12/8/22				
SHEET	1	DSGN	DWG	CHK	

IVGID REQUIREMENTS FOR CONSTRUCTION OF WATER & SEWER

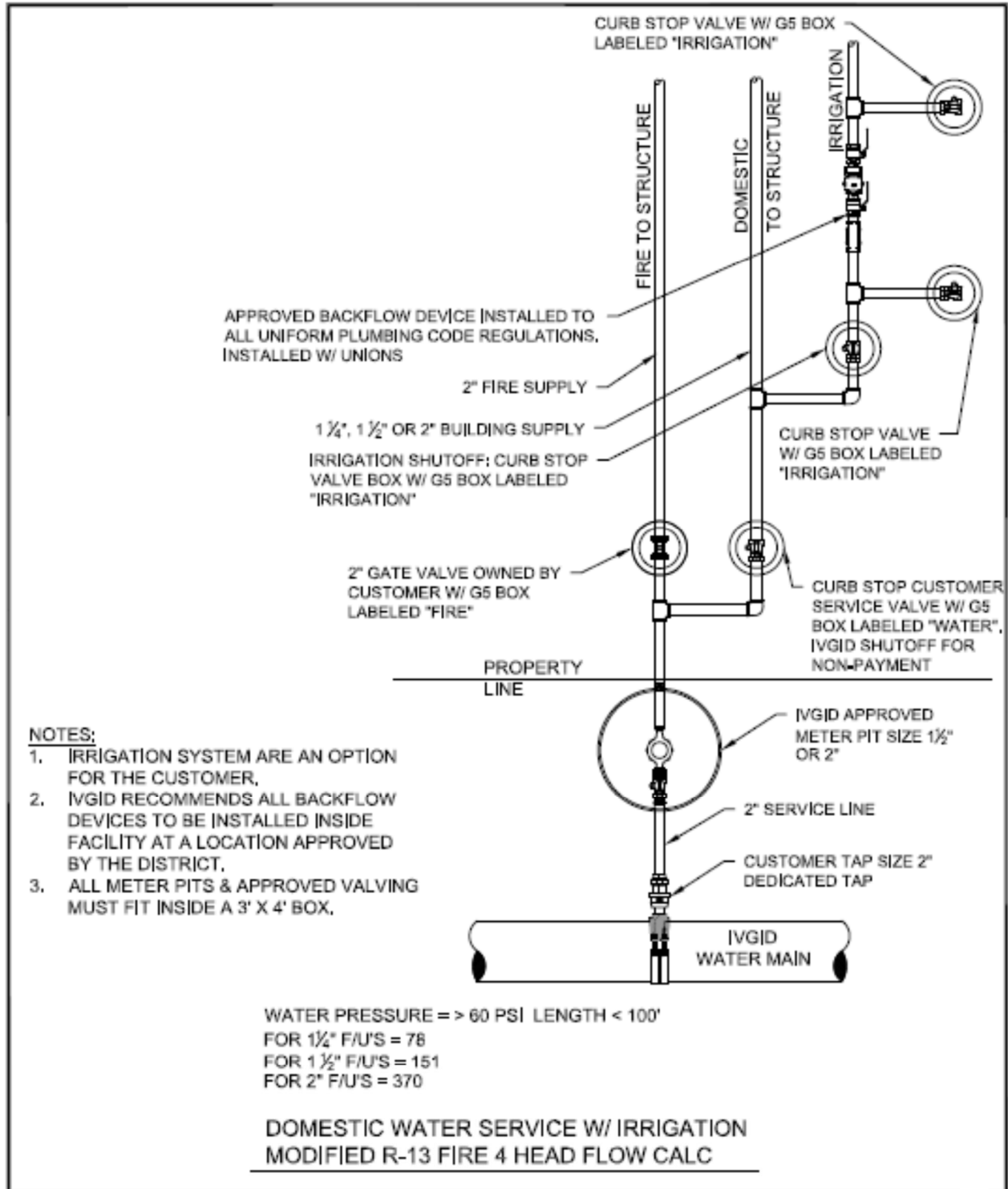

NOTES:

1. IRRIGATION SYSTEM ARE AN OPTION FOR THE CUSTOMER,
2. IVGID RECOMMENDS ALL BACKFLOW DEVICES TO BE INSTALLED INSIDE FACILITY AT A LOCATION APPROVED BY THE DISTRICT.
3. ALL METER PITS & APPROVED VALVING MUST FIT INSIDE A 3' X 4' BOX.

PROJECT	STD DETAILS					INCLINE VILLAGE GENERAL IMPROVEMENT DISTRICT <small>1220 SWEETWATER RD. INCLINE VILLAGE, NV 89401 P: 877.468.4397</small>			
SCALE	ND								
DATE	12/9/22								
SHEET	1	DISGN	DWG	CHK					

IVGID REQUIREMENTS FOR CONSTRUCTION OF WATER & SEWER

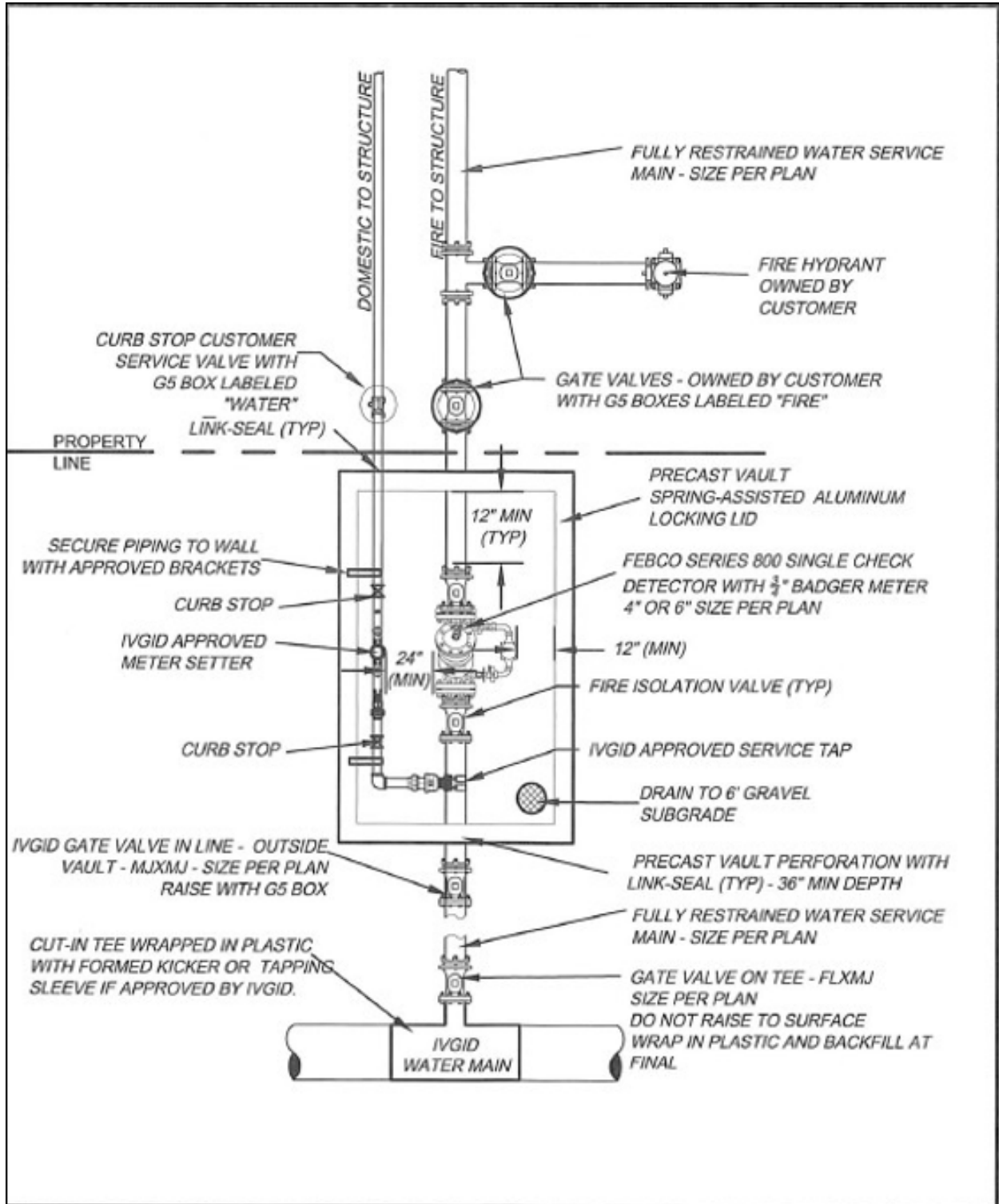

Project No. _____ DATE: 28 FEB 2017 SCALE: N.T.S. DRAWN: MEL DESIGN APPROVED: _____ DATE: _____	INCLINE VILLAGE GENERAL IMPROVEMENT DISTRICT 1220 Sweetwater Rd.; Incline Village, Nevada 89451 Phone 775-832-1267 METERED DOMESTIC AND DETECTOR CHECK FIRE WATER SERVICES	
---	---	---

IVGID REQUIREMENTS FOR CONSTRUCTION OF WATER & SEWER

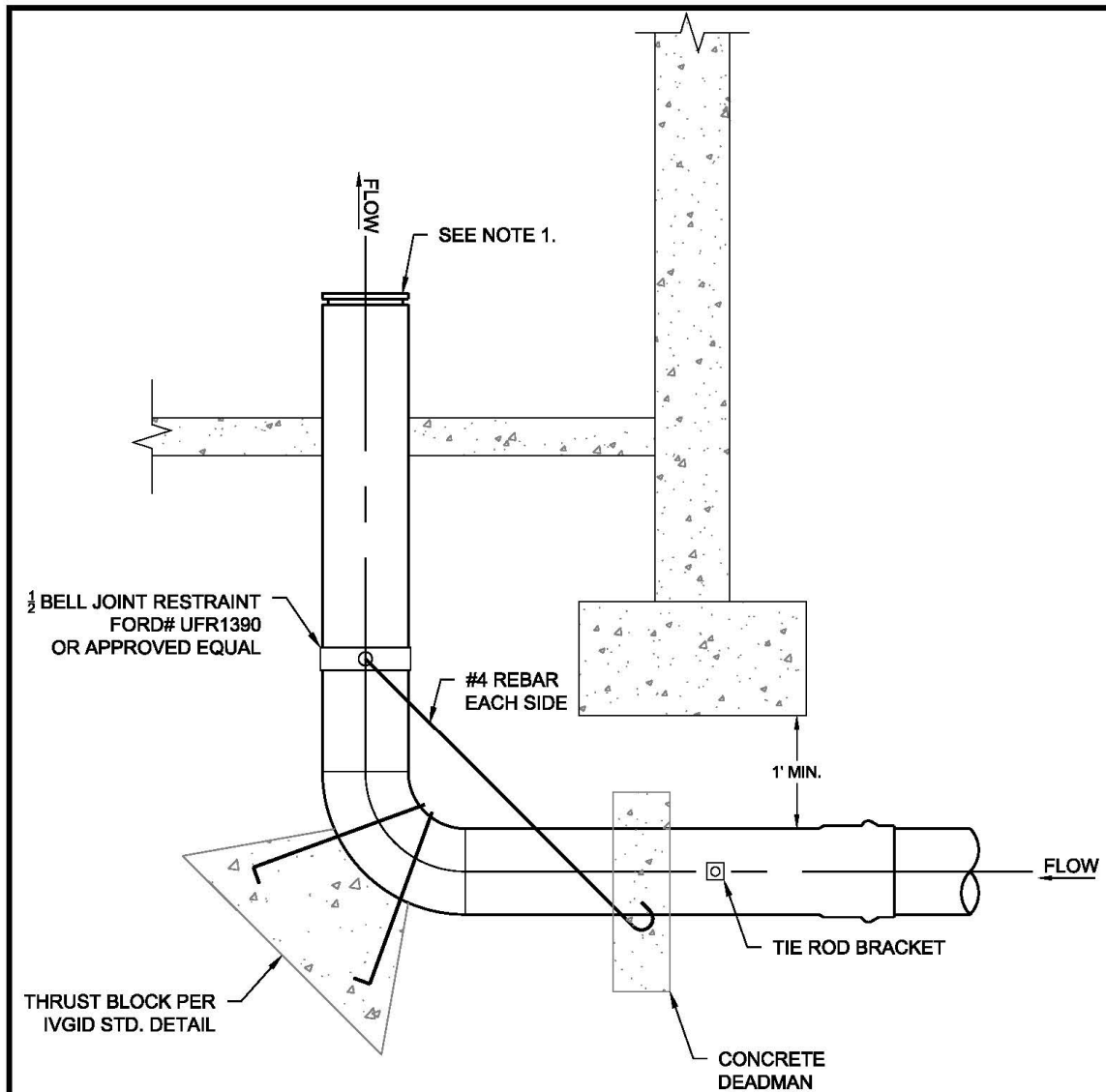

- NOTES:**
 1. ONE PIECE STAINLESS STEEL RISER. SEE IVGID SPEC SHEET.

U:\Engineering\AUTOCAD\Utility\Water\standard details\IVGID Water Services\FIRE RISER.dwg

Project No. _____ DATE: 19 FEB 2020 SCALE: N.T.S. DRAWN: NPC DESIGN: APPROVED: _____ DATE: _____	INCLINE VILLAGE GENERAL IMPROVEMENT DISTRICT 1220 Sweetwater Rd.; Incline Village, Nevada 89451 PHONE 775-832-1287	
1-PIECE FIRE RISER		

IVGID REQUIREMENTS FOR CONSTRUCTION OF WATER & SEWER

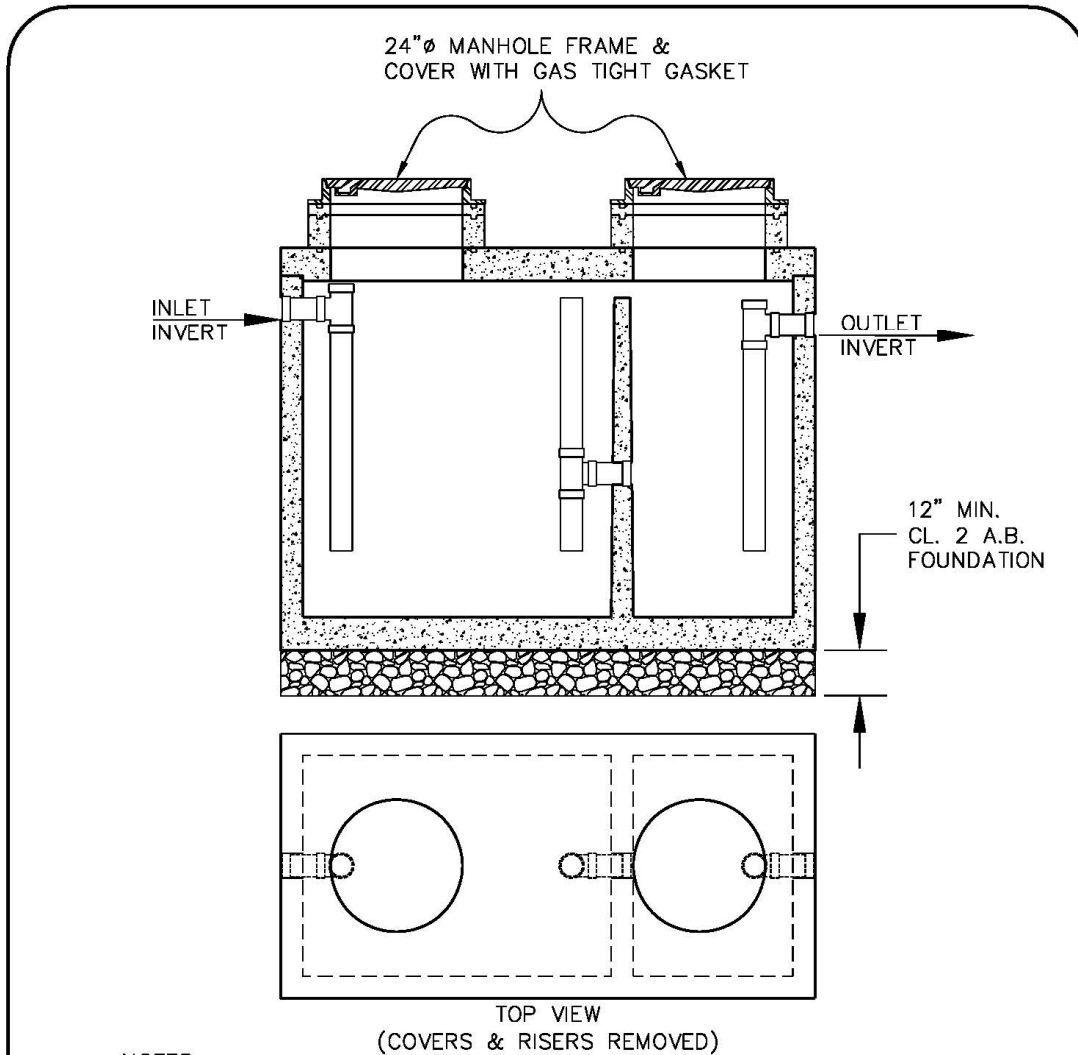

NOTES:

1. MINIMUM CAPACITY 500 GALLONS.
2. VAULT AND MANHOLE DESIGN LOAD: H-20 TRAFFIC LOADING.
3. 24"Ø MANHOLE FRAME & COVERS: PER IVGID STD. DETAIL. ADD THIRD MANHOLE OVER CENTRAL STANDPIPE FOR INTERCEPTORS LARGER THAN 1,000 GALLONS.
4. SET VAULT LEVEL
5. RAMNEK PRIMER AND SEALANT SHALL BE APPLIED TO BOTH SURFACES AT ALL JOINTS.

SCALE: N.T.S.

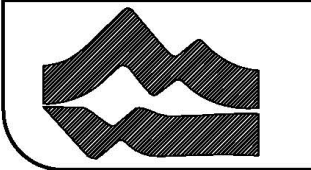

**GREASE
INTERCEPTOR**

IVGID REQUIREMENTS FOR CONSTRUCTION OF WATER & SEWER

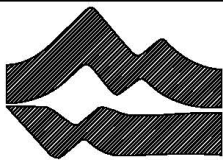
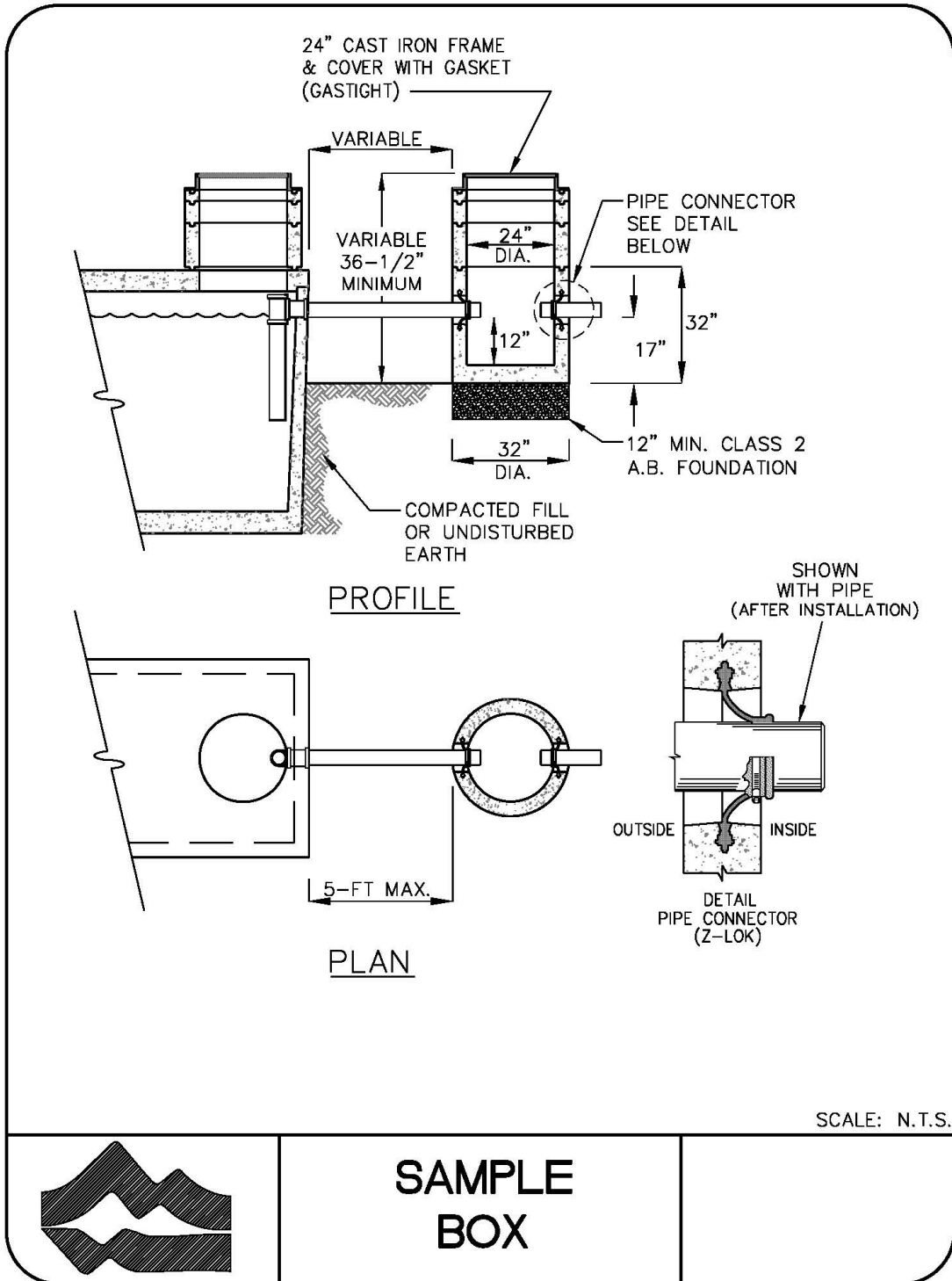

**SAMPLE
BOX**

IVGID REQUIREMENTS FOR CONSTRUCTION OF WATER & SEWER

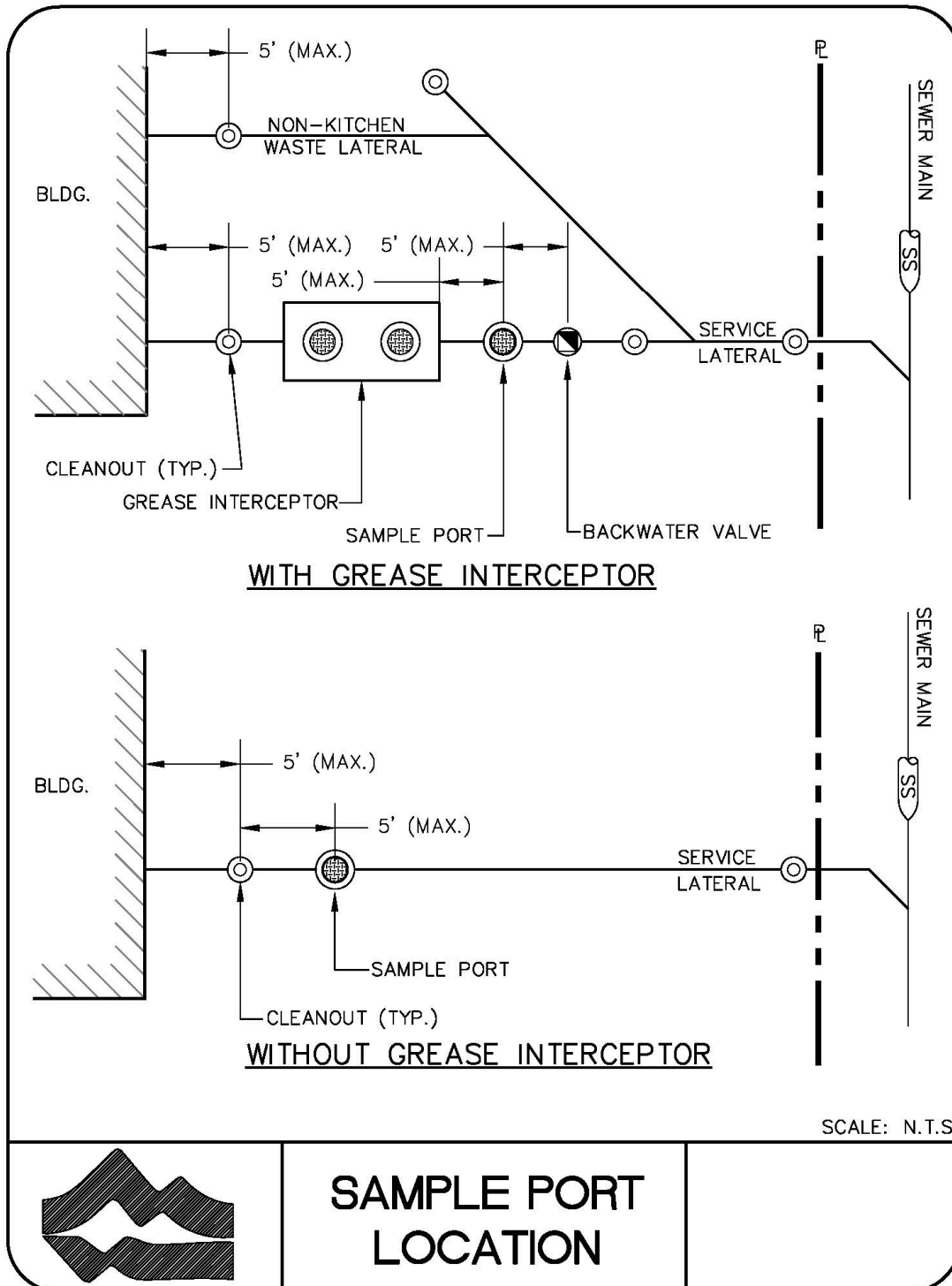

IVGID REQUIREMENTS FOR CONSTRUCTION OF WATER & SEWER

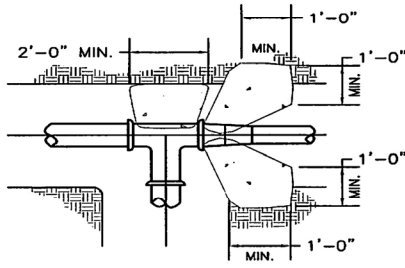

REDUCERS - PLAN

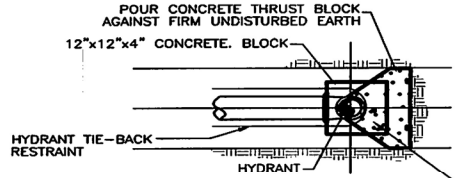

FIRE HYDRANT
END CAP DETAIL - PLAN

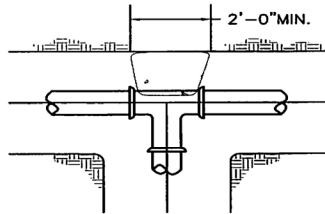

TEES - PLAN

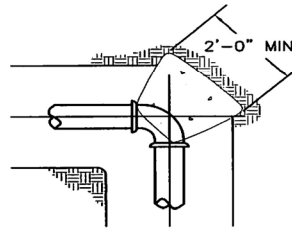

ALL BENDS - PLAN

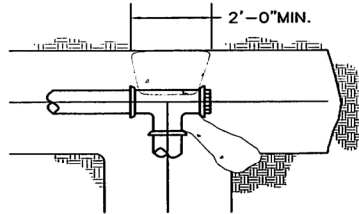

TEE W/PLUG

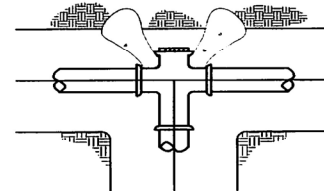

CROSS W/PLUG

NOTE:

1. ALL FITTINGS TO BE WRAPPED IN PLASTIC.
2. CONCRETE SHALL NOT TOUCH PIPE OR BOLTS.
3. THRUST BLOCKS TO BE 6.25 SACK, 4000 PSI (MIN) STRENGTH CONCRETE

NOTE:

THIS DETAIL APPLIES FOR ALL FITTINGS.

SIDE WALLS OF TRENCH

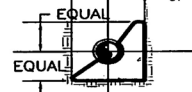

TYPICAL SECTION

TYPE OF FITTING	BEARING AREA OF THRUST BLOCKS--SQ.FT.					
	90° BEND	45° BEND	1 1/4" OR 2 1/2" BEND	TEE OR DEAD END	TEE WITH PLUG	CROSS W/PLUG
4"	2	1	1	2	2	2
6"	4	4	2	4	4	4
8"	7	4	2	5	7	7
10"	12	6	3	8	12	12
12"	16	10	5	12	16	16
14"	20	12	6	14	20	20
16"	27	15	8	18	27	27
18"	45	25	13	32	45	45
24"	65	35	18	46	65	65

HORIZONTAL THRUST BLOCK DETAILS

NOT TO SCALE

IVGID REQUIREMENTS FOR CONSTRUCTION OF WATER & SEWER

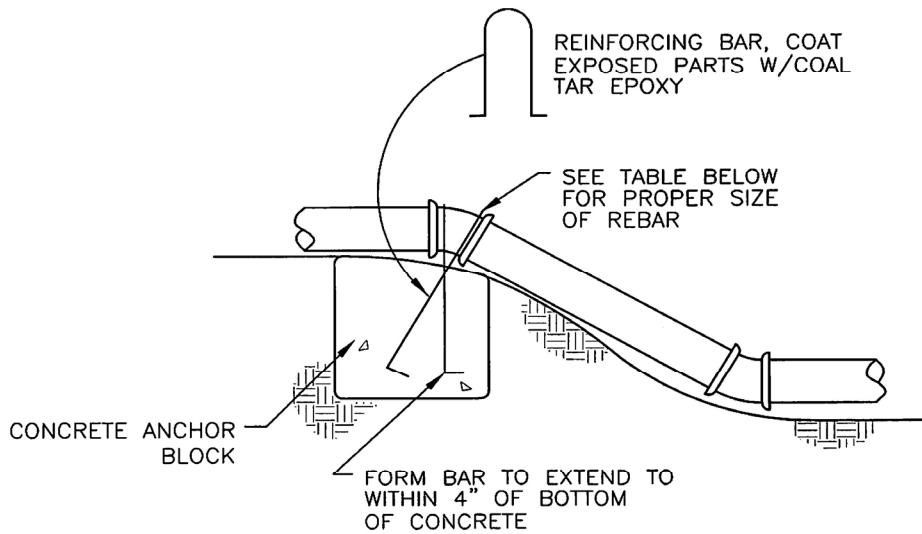

ELEVATION

1. ALL FITTINGS TO BE WRAPPED IN PLASTIC.
2. CONCRETE SHALL NOT TOUCH PIPE OR BOLTS.
3. THRUST BLOCKS TO BE 6.25 SACK, 4000 PSI (MIN) STRENGTH CONCRETE

<u>REQUIRED ANCHOR BLOCK – CUBIC FEET CONCRETE</u>					
<u>PIPE SIZE</u>	<u>4"</u>	<u>6"</u>	<u>8"</u>	<u>10"</u>	<u>12"</u>
<u>11-1/4' BEND</u>	2	7	13	20	31
<u>22-1/2' BEND</u>	5	14	26	40	59
<u>45° BEND</u>	10	28	52	80	117
<u>BAR SIZE (MINIMUM)</u>	#4	#4	#5	#5	#8

VERTICAL THRUST ANCHORAGE

NOT TO SCALE

IVGID REQUIREMENTS FOR CONSTRUCTION OF WATER & SEWER

Typical approved wet well, four float system with grinding, alternating pumps. Three Hundred (300) gallons of storage must be provided above the highest float (High Water Float Switch) any variances to this must be approved by the IVGID Compliance Department. Wet well Storage Chambers must be constructed of Concrete, Polyethylene, or fiberglass equipped with the required inlets and outlets. Each wet well shall be equipped with an approved check or isolating valve.

TYPICAL APPLICATIONS

FLOAT BRACKET

PAGE
2

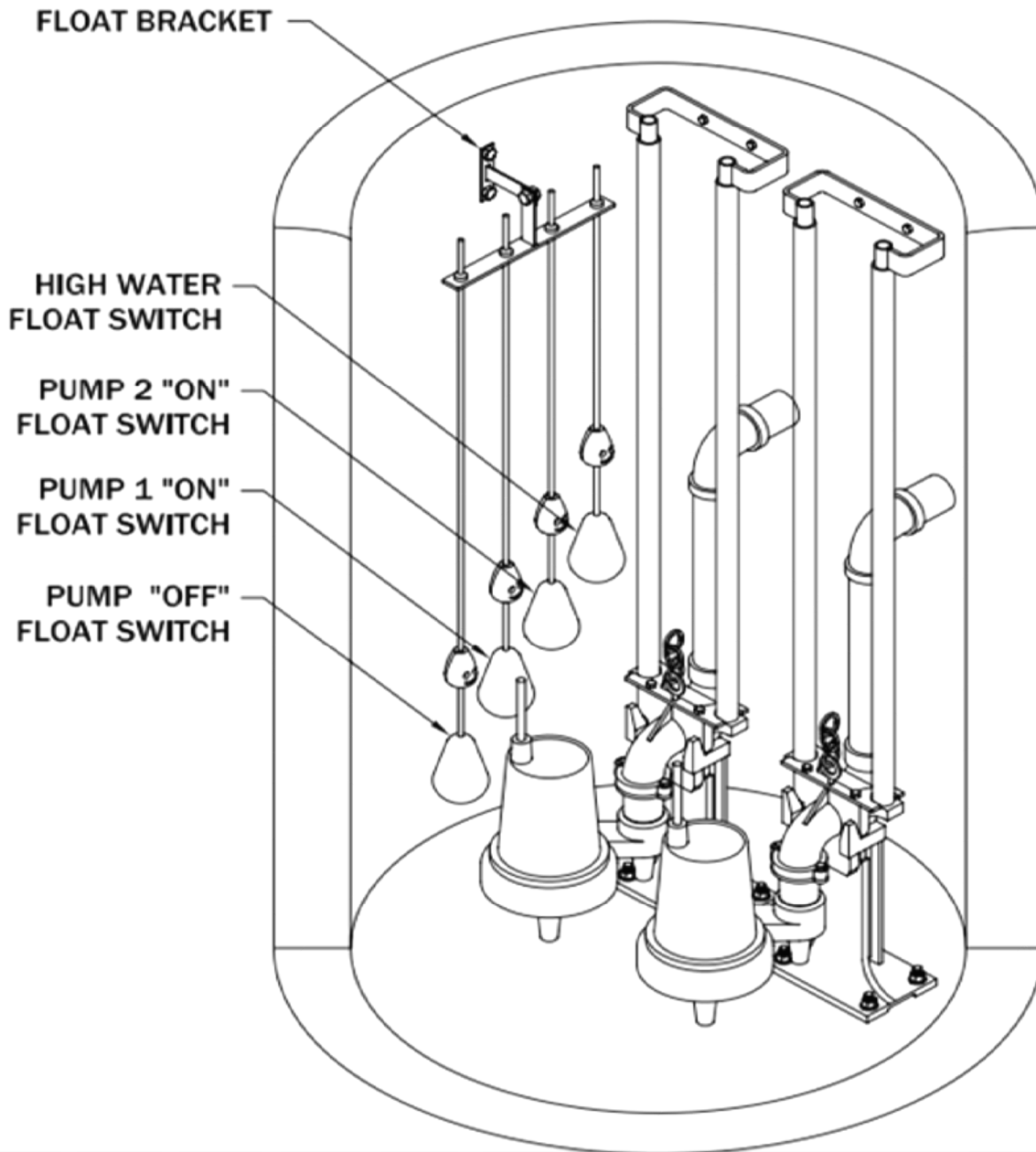

IVGID REQUIREMENTS FOR CONSTRUCTION OF WATER & SEWER

Please direct any questions to IVGID Compliance. Thank you for your cooperation.

Kate Nelson

Engineering Manager

775-832-1372 Office
npc@ivgid.org

Tim Buxton

Chief Inspector

775-832-1246 Office
775-354-5664 Cell
tlb@ivgid.org

Drew Morris

Inspector

775-832-2014 Office
775-745-7577 Cell
dnm@ivgid.org

Jeff Donahue

Inspector

775-832-1314 Office
775-313-4088 Cell
jad@ivgid.org
jad@ivgid.org

Inspection Hotline

775-832-1224

All inspections require 48-hour notice